



**TENDER FOR CONSTRUCTION OF SOLAR-POWERED  
ELECTRIC PERIMETER FENCE FOR KAPCHUMBE  
FOREST BLOCK, CHEPALUNGU FOREST STATION IN  
BOMET COUNTY**

**Issued on: 18<sup>th</sup> February 2025**

**OCB No: KFS/GZDSP11/002/2024-2025**

**Employer: Kenya Forest Service**

**Country: Kenya**

# Preface

This Bidding Document for Procurement of Small Works has been prepared by Kenya Forest Service and is based on the Standard Bidding Document for Procurement of Small Works issued by the African Development Bank,<sup>1</sup> dated June 2010.

This document reflects the structure and the provisions of the Master Document for Procurement of Small Works, prepared by Multilateral Development Banks and International Financing Institutions, except where specific considerations within the African Development Bank have required a change.

## Standard Bidding Document

### Table of Contents

<b>PART 1 – Bidding Procedures .....</b>	<b>3</b>
Section I. Instructions to Bidders .....	5
Section II. Bid Data Sheet .....	27
Section III. Evaluation and Qualification Criteria.....	32
Section IV. Bidding Forms.....	43
Section V. Eligible Countries.....	81
<b>PART 2 – Employer’s Requirements .....</b>	<b>83</b>
Section VI. Requirements.....	85
<b>PART 3 – Conditions of Contract and Contract Forms.....</b>	<b>89</b>
Section VII. General Conditions (GC).....	91
Section VIII. Particular Conditions .....	127
Section IX. Contract Forms.....	133

---

# **PART 1 – Bidding Procedures**



## Section I. Instructions to Bidders

### Table of Contents

<b>A.</b>	<b>General.....</b>	<b>7</b>
1.	Scope of Bid.....	7
2.	Source of Funds .....	7
3.	Fraud and Corruption .....	7
4.	Eligible Bidders.....	9
5.	Eligible Goods and Related Services .....	10
<b>B.</b>	<b>Contents of Bidding Document .....</b>	<b>11</b>
6.	Sections of Bidding Document .....	11
7.	Clarification of Bidding Document, Site Visit, Pre-Bid Meeting .....	12
8.	Amendment of Bidding Document .....	13
<b>C.</b>	<b>Preparation of Bids .....</b>	<b>13</b>
9.	Cost of Bidding .....	13
10.	Language of Bid.....	13
11.	Documents Comprising the Bid .....	13
12.	Letter of Bid and Price Schedules .....	14
13.	Alternative Bids .....	14
14.	Bid Prices and Discounts.....	15
15.	Currencies of Bid and Payment.....	16
16.	Documents Establishing the Qualifications of the Bidder .....	16
17.	Documents Establishing the Eligibility of the Goods and Related Services.....	16
18.	Period of Validity of Bids .....	16
19.	Bid Security.....	16
20.	Format and Signing of Bid.....	18
<b>D.</b>	<b>Submission and Opening of Bids .....</b>	<b>19</b>
21.	Submission, Sealing and Marking of Bids .....	19
22.	Deadline for Submission of Bids .....	19
23.	Late Bids .....	19
24.	Withdrawal, Substitution, and Modification of Bids .....	20
25.	Bid Opening .....	20

---

<b>E.</b>	<b>Examination of Bids.....</b>	<b>21</b>
26.	Confidentiality.....	21
27.	Clarification of Bids.....	22
28.	Determination of Responsiveness.....	22
<b>F.</b>	<b>Bid Evaluation and Comparison.....</b>	<b>23</b>
29.	Correction of Arithmetical Errors.....	23
30.	Conversion to Single Currency.....	23
31.	Bid Adjustments.....	23
32.	Qualification of the Bidder.....	24
33.	Comparison of Bid.....	25
34.	Employer’s Right to Accept Any Bid, and to Reject Any or All Bids.....	25
<b>G.</b>	<b>Award of Contract.....</b>	<b>25</b>
35.	Award Criteria.....	25
36.	Notification of Award.....	25
37.	Signing of Contract.....	25
38.	Performance Security.....	26

# Section I. Instructions to Bidders

## A. General

1. **Scope of Bid**
  - 1.1 The Employer indicated in Section II, **Bid Data Sheet (BDS)** issues this Bidding Document for the procurement of Works, as specified in Section VI, Requirements. The name, identification, and number of lots are provided in the **BDS**.
  - 1.2 Unless otherwise stated, throughout this Bidding Document definitions and interpretations shall be as prescribed in Section VII, **General Conditions**.
2. **Source of Funds**
  - 2.1 The Borrower or Recipient (hereinafter called “Borrower”) indicated in the **BDS** has applied for or received financing (hereinafter called “funds”) from the African Development Bank<sup>2</sup> (hereinafter called “the Bank”) toward the cost of the project named in the **BDS**. The Borrower intends to apply a portion of the funds to eligible payments under the contract(s) for which this Bidding Document is issued.
  - 2.2 Payments by the Bank will be made only at the request of the Borrower and upon approval by the Bank in accordance with the terms and conditions of the financing agreement between the Borrower and the Bank (hereinafter called the Loan Agreement), and will be subject in all respects to the terms and conditions of that Loan Agreement. No party other than the Borrower shall derive any rights from the Loan Agreement or have any claim to the funds.
3. **Fraud and Corruption**
  - 3.1 It is the Bank’s policy to require that Borrowers (including beneficiaries of Bank Financing), as well as bidders, suppliers, and contractors, and their subcontractors, under Bank-financed contracts, observe the highest standard of ethics during the procurement and execution of such contracts. In pursuance of this policy<sup>3</sup>, the Bank:
    - (a) defines, for the purposes of this provision, the terms set forth below as follows:
      - (i) “Corrupt Practice” is the offering, giving, receiving, or soliciting, directly or indirectly, of anything of value to

<sup>2</sup> The specific financing institution shall be as stipulated in the **BDS**.

<sup>3</sup> See the Bank’s “Rules and Procedures for Whistleblowing and Complaints Handling in the Bank”; and the “Guidelines for Preventing & Combating Corruption & Fraud in Bank Group Operations”

influence improperly the actions of another party;

- (ii) “Fraudulent Practice” any act or omission, including a misrepresentation that knowingly or recklessly misleads, or attempts to mislead, a party to obtain financial or other benefit or to avoid an obligation;
  - (iii) “Collusive Practice” is an arrangement between two or more parties, designed to achieve an improper purpose, including to influence improperly the actions of another party; and
  - (iv) “Coercive Practice” is impairing or harming, or threatening to impair or harm, directly or indirectly, any party or the property of the party to influence improperly the actions of a party;
- (b) will reject a proposal for award if it determines that the bidder recommended for award has, directly or through an agent, engaged in Corrupt, Fraudulent, Collusive, or Coercive Practices in competing for the contract in question;
  - (c) will cancel the portion of the Financing allocated to a contract if it determines at any time that representatives of the Borrower or of a beneficiary of such Financing engaged in Corrupt, Fraudulent, Collusive, or Coercive Practices during the procurement or the execution of that contract, without the Borrower having taken timely and appropriate action satisfactory to the Bank to address such practices when they occur;
  - (d) will sanction a firm or individual, including declaring such firm or individual ineligible to bid for, or to be awarded Bank-financed contracts either indefinitely or for a stated period of time, if it at any time determines that the firm or individual has, directly or through an agent, engaged in Corrupt, Fraudulent, Collusive, or Coercive Practices in competing for, or in executing, a Bank-financed contract; and
  - (e) will have the right to require that a provision be included in bidding documents and in contracts financed by the Bank, requiring bidders, suppliers and contractors to permit the Bank to inspect their accounts and records and other documents relating to the bid submission and contract performance and to have them audited by auditors appointed by the Bank.
- 3.2 Furthermore, Bidders shall be aware of the provisions stated in Section VII, **General Conditions**.



- 4. Eligible Bidders**
- 4.1 A Bidder may be a natural person, private entity, government-owned entity—subject to **ITB** 4.5—or any combination of such entities supported by a letter of intent to enter into an agreement or under an existing agreement in the form of a joint venture, consortium, or association (JVCA). In the case of a joint venture, consortium, or association:
- (a) unless otherwise specified in the **BDS**, all partners shall be jointly and severally liable, and
  - (b) the JVCA shall nominate a Representative who shall have the authority to conduct all businesses for and on behalf of any and all the partners of the JVCA during the bidding process and, in the event the JVCA is awarded the Contract, during contract execution.
- 4.2 A Bidder, and all parties constituting the Bidder, shall have the nationality of an eligible country, in accordance with the Bank's **Rules and Procedures for Procurement of Goods and Works**, and as listed in Section V, Eligible Countries.<sup>4</sup> A Bidder shall be deemed to have the nationality of a country if the Bidder is a citizen or is constituted, incorporated, or registered and operates in conformity with the provisions of the laws of that country. This criterion shall also apply to the determination of the nationality of proposed subcontractors or suppliers for any part of the Contract including Related Services.
- 4.3 A Bidder shall not have a conflict of interest. All Bidders found to have a conflict of interest shall be disqualified. A Bidder may be considered to have a conflict of interest with one or more parties in this bidding process, if:
- (a) they have controlling partners in common; or
  - (b) they receive or have received any direct or indirect subsidy from any of them; or
  - (c) they have the same legal representative for purposes of this bid; or
  - (d) they have a relationship with each other, directly or through common third parties, that puts them in a position to have access to information about or influence on the bid of another Bidder, or influence the decisions of the Employer regarding this bidding process; or
  - (e) a Bidder participates in more than one bid in this bidding

---

<sup>4</sup> Including eligibility criteria for participation in the supply of goods, works and related services.

process. Participation by a Bidder in more than one Bid will result in the disqualification of all Bids in which it is involved. However, this does not limit the inclusion of the same subcontractor, not otherwise participating as a Bidder, in more than one bid; or

- (f) a Bidder participated as a consultant in the preparation of Section VI, Requirements that are the subject of the bid.
- (g) a Bidder or any of its affiliates has been hired, or is proposed to be hired, by the Employer or the Borrower for the supervision of the contract.

4.4 A Bidder that is under a declaration of ineligibility by the Bank in accordance with **ITB** Clause 3, at the date of the deadline for bid submission or thereafter, shall be disqualified.

4.5 Government-owned entities in the Borrower's country shall be eligible only if they can establish that they (i) are legally and financially autonomous, (ii) operate under the principles of commercial law, and (iii) are not dependent agencies of the Employer or the Borrower.

4.6 Bidders shall not be under execution of a Bid-Securing Declaration in the Employer's Country.

4.7 Bidders shall provide such evidence of their continued eligibility satisfactory to the Employer, as the Employer shall reasonably request.

4.8 Firms from an eligible country shall be excluded if:

- (a) as a matter of law or official regulation, the Borrower's country prohibits commercial relations with that country; or
- (b) by an act of compliance with a decision of the United Nations Security Council taken under Chapter VII of the Charter of the United Nations, the Borrower's country prohibits any import of Goods from that country or any payments to persons or entities in that country.

4.9 In case a prequalification process has been conducted prior to the bidding process, this bidding is open only to prequalified Bidders.

## **5. Eligible Goods and Related Services**

5.1 All Goods and Related Services to be supplied under the Contract and financed by the Bank, shall have as their country of origin an eligible country of the Bank in accordance with the Bank's **Rules and Procedures for Procurement of Goods and Works**, as listed

in Section V, Eligible Countries.

- 5.2 For purposes of this Clause, the term “Goods” includes commodities, raw material, machinery, equipment, and industrial plants; and “Related Services” includes services such as insurance, transportation, installation, commissioning, training, and initial maintenance.
- 5.3 The term “country of origin” means the country where the Goods have been mined, grown, cultivated, produced, manufactured, or processed; or through manufacture, processing, or assembly, another commercially recognized article results that differs substantially in its basic characteristics from its imported components.
- 5.4 The nationality of the firm that produces, assembles, distributes, or sells the Goods shall not determine their origin.

## **B. Contents of Bidding Document**

### **6. Sections of Bidding Document**

- 6.1 The Bidding Document consist of Parts 1, 2, and 3, which include all the Sections indicated below, and should be read in conjunction with any Addenda issued in accordance with **ITB 8**.

#### **PART 1 Bidding Procedures**

- Section I. Instructions to Bidders (**ITB**)
- Section II. Bid Data Sheet (**BDS**)
- Section III. Evaluation and Qualification Criteria
- Section IV. Bidding Forms
- Section V. Eligible Countries

#### **PART 2 Employer’s Requirements**

- Section VI. Requirements

#### **PART 3 Conditions of Contract and Contract Forms**

- Section VII. General Conditions (**GC**)
- Section VIII. Particular Conditions (**PC**)
- Section IX. Contract Forms

- 6.2 The Invitation for Bids issued by the Employer is not part of the Bidding Document.
- 6.3 The Bidder shall obtain the Bidding Document from the source stated by the Employer in the Invitation for Bids; otherwise the Employer is not responsible for the completeness of the Bidding

Document.

- 6.4 The Bidder is expected to examine all instructions, forms, terms, and specifications in the Bidding Document. Failure to furnish all information or documentation required by the Bidding Document may result in the rejection of the bid.

**7. Clarification of Bidding Document, Site Visit, Pre-Bid Meeting**

- 7.1 A prospective Bidder requiring any clarification of the Bidding Document shall contact the Employer in writing at the Employer's address indicated in the **BDS** or raise his enquiries during the pre-bid meeting if provided for in accordance with **ITB** 7.4. The Employer will respond to any request for clarification, provided that such request is received prior to the deadline for submission of bids, within the number of days specified in the **BDS**. The Employer response shall be in writing with copies to all Bidders who have acquired the Bidding Document in accordance with **ITB** 6.3, including a description of the inquiry but without identifying its source. Should the Employer deem it necessary to amend the Bidding Document as a result of a request for clarification, it shall do so following the procedure under **ITB** 8 and **ITB** 22.2.

- 7.2 Where applicable, the Bidder is advised to visit and examine the project site and obtain for itself on its own responsibility all information that may be necessary for preparing the bid and entering into a contract for the provision of the Requirements. The costs of visiting the site shall be at the Bidder's own expense.

- 7.3 Pursuant to **ITB** 7.2, where the Bidder and any of its personnel or agents have been granted permission by the Employer to enter upon its premises and lands for the purpose of such visit, the Bidder, its personnel, and agents will release and indemnify the Employer and its personnel and agents from and against all liability in respect thereof, and will be responsible for death or personal injury, loss of or damage to property, and any other loss, damage, costs, and expenses incurred as a result of the visit.

- 7.4 The Bidder's designated representative is invited to attend a pre-bid meeting, if provided for in the **BDS**. The purpose of the meeting will be to clarify issues and to answer questions on any matter that may be raised at that stage. If so provided for in the **BDS**, the Employer will organize a site visit.

- 7.5 The Bidder is requested, as far as possible, to submit any questions in writing, to reach the Employer not later than one week before the meeting.

- 7.6 Minutes of the pre-bid meeting, including the text of the questions raised without identifying the source, and the responses given,

together with any responses prepared after the meeting, will be transmitted promptly to all Bidders who have acquired the Bidding Document in accordance with **ITB** 6.3. Any modification to the Bidding Document that may become necessary as a result of the pre-bid meeting shall be made by the Employer exclusively through the issue of an Addendum pursuant to **ITB** 8 and not through the minutes of the pre-bid meeting.

7.7 Non-attendance at the pre-bid meeting will not be a cause for disqualification of a Bidder.

**8. Amendment of Bidding Document**

8.1 At any time prior to the deadline for submission of bids, the Employer may amend the Bidding Document by issuing addenda.

8.2 Any addendum issued shall be part of the Bidding Document and shall be communicated in writing to all who have obtained the Bidding Document from the Employer in accordance with **ITB** 6.3.

8.3 To give prospective Bidders reasonable time in which to take an addendum into account in preparing their bids, the Employer may, at its discretion, extend the deadline for the submission of bids, pursuant to **ITB** 22.2

**C. Preparation of Bids**

**9. Cost of Bidding**

9.1 The Bidder shall bear all costs associated with the preparation and submission of its Bid, and the Employer shall not be responsible or liable for those costs, regardless of the conduct or outcome of the bidding process.

**10. Language of Bid**

10.1 The Bid, as well as all correspondence and documents relating to the bid exchanged by the Bidder and the Employer, shall be written in the language specified in the **BDS**. Supporting documents and printed literature that are part of the Bid may be in another language provided they are accompanied by an accurate translation of the relevant passages in that language, in which case, for purposes of interpretation of the Bid, such translation shall govern.

**11. Documents Comprising the Bid**

11.1 The Bid shall comprise the following:

- (a) Letter of Bid
- (b) Completed Schedules as provided in Section IV, Bidding Forms;
- (c) Bid Security or Bid-Securing Declaration, in accordance with **ITB** 19;
- (d) at the Bidder's option, alternative proposals, if permissible,

in accordance with **ITB** 13;

- (e) written confirmation authorizing the signatory of the Bid to commit the Bidder, in accordance with **ITB** 20.2;
- (f) documentary evidence establishing the eligibility of the Goods and Related Services offered by the Bidder, in accordance with **ITB** 17.1;
- (g) documentary evidence establishing the Bidder's qualifications in accordance with the requirements of Section III, Evaluation and Qualification Criteria, using the relevant forms furnished in Section IV, Bidding Forms;
- (h) documentary evidence as specified in the **BDS**, establishing the conformity of the Technical Proposal offered by the Bidder with the Bidding Document, using the relevant forms furnished in Section IV, Bidding Forms;
- (i) in the case of a bid submitted by a JVCA, JVCA agreement, or letter of intent to enter into a JVCA including a draft agreement, indicating at least the parts of the Requirements to be executed by the respective partners;
- (j) any other document required in the **BDS**.

**12. Letter of Bid and Price Schedules**

12.1 The Bidder shall submit the Letter of Bid using the form furnished in Section IV, Bidding Forms. This form must be completed without any alterations to its format, and no substitutes shall be accepted. All blank spaces shall be filled in with the information requested.

**13. Alternative Bids**

13.1 Unless otherwise indicated in the **BDS**, alternative proposals shall not be considered. If alternative proposals are permitted, their method of evaluation shall be as stipulated in Section III, Evaluation and Qualification Criteria.

13.2 When alternative times for completion are explicitly invited, a statement to that effect will be included in the **BDS**, as well as the method of evaluating different times for completion.

13.3 Except as provided under **ITB** 13.4 below, Bidders wishing to offer technical alternatives to the requirements of the bidding document must first price the Employer's requirements as described in the bidding document and shall further provide all information necessary for a complete evaluation of the alternative by the Employer, including drawings, design calculations, technical specifications, breakdown of prices, and proposed construction methodology and other relevant details. Only the technical

alternatives, if any, of the lowest evaluated Bidder conforming to the basic technical requirements shall be considered by the Employer.

13.4 When specified in the **BDS**, Bidders are permitted to submit alternative technical solutions for specified parts of the requirements, and such parts shall be identified in the **BDS**, as will the method for their evaluation, and described in Section VI, Requirements.

#### **14. Bid Prices and Discounts**

14.1 The prices and discounts quoted by the Bidder in the Letter of Bid and in the Price Schedules shall conform to the requirements specified in **ITB 14.2**.

14.2 Unless otherwise provided in the **BDS** and the **General Conditions (GC)**, the prices quoted by the Bidder shall be fixed.

14.3 The Bidder shall submit a bid for the whole of the works described in **ITB 1.1** by filling in prices for all items of the Works, as identified in Section IV, Bidding Forms. In case of admeasurement contracts, the Bidder shall fill in rates and prices for all items of the Works described in the Bill of Quantities. Items against which no rate or price is entered by the Bidder will not be paid for by the Employer when executed and shall be deemed covered by the rates for other items and prices in the Bill of Quantities.

14.4 The price to be quoted in the Letter of Bid shall be the total price of the Bid, excluding any discounts offered.

14.5 Unconditional discounts, if any, and the methodology for their application shall be quoted in the Letter of Bid, in accordance with **ITB 12.1**.

14.6 If, pursuant to **ITB 14.2**, prices are adjustable, the Bidder shall furnish the indices and weightings for the price adjustment formula in the Schedule of Adjustment Data in Section IV (Bidding Forms) and the Employer may require the Bidder to justify its proposed indices and weightings.

14.7 If so indicated in **ITB 1.1**, bids are invited for individual contracts or for any combination of contracts (packages). Bidders wishing to offer any price reduction for the award of more than one Contract shall specify in their bid the price reductions applicable to each package, or alternatively, to individual Contracts within the package. Price reductions or discounts shall be submitted in accordance with **ITB 14.5**, provided the bids for all contracts are submitted and opened at the same time.

14.8 All duties, taxes, and other levies payable by the Contractor under the Contract, or for any other cause, as of the date 28 days prior to

the deadline for submission of bids, shall be included in the rates and prices and the total bid price submitted by the Bidder.

- 15. Currencies of Bid and Payment**
- 15.1 The currency(ies) of the bid and the currency(ies) for payment shall be as specified in the **BDS**.
- 16. Documents Establishing the Qualifications of the Bidder**
- 16.1 To establish its qualifications to perform the Contract in accordance with Section III, Evaluation and Qualification Criteria, the Bidder shall provide the information requested in Section IV, Bidding Forms.
- 16.2 Bidders, individually or in joint ventures, applying for eligibility for margin of preference, if such margin applies pursuant to **ITB 31.2**, shall supply all information required to satisfy the criteria for eligibility as described in **ITB 31.2**.
- 17. Documents Establishing the Eligibility of the Goods and Related Services**
- 17.1 To establish the eligibility of the Goods and Related Services in accordance with **ITB** Clause 5, Bidders shall complete the forms, included in Section IV, Bidding Forms.
- 18. Period of Validity of Bids**
- 18.1 Bids shall remain valid for the period specified in the **BDS** after the bid submission deadline date prescribed by the Employer. A bid valid for a shorter period shall be rejected by the Employer as non-responsive.
- 18.2 In exceptional circumstances, prior to the expiration of the bid validity period, the Employer may request Bidders to extend the period of validity of their bids. The request and the responses shall be made in writing. If a bid security is requested in accordance with **ITB 19**, the Bidder granting the request shall also extend the bid security for twenty-eight (28) days beyond the deadline of the extended validity period. A Bidder may refuse the request without forfeiting its bid security. A Bidder granting the request shall not be required or permitted to modify its bid, except as provided in **ITB 18.3**.
- 18.3 In the case of fixed price contracts, if the award is delayed by a period exceeding fifty-six (56) days beyond the expiry of the initial bid validity, the Contract price shall be adjusted as specified in the request for extension. Bid evaluation shall be based on the Bid Price without taking into consideration the above correction.
- 19. Bid Security**
- 19.1 The Bidder shall furnish as part of its bid, at the option of the Employer, and as stipulated in the **BDS**, the original of either a Bid-Securing Declaration or a bid security using the relevant form included in Section IV, Bidding Forms. In the case of a bid



security, the bid security amount and currency shall be as specified in the **BDS**.

19.2 A Bid-Securing Declaration shall use the form included in Section IV, Bidding Forms.

19.3 If a bid security is specified pursuant to **ITB** 19.1, the bid security shall be a demand guarantee in any of the following forms at the Bidder's option:

- (a) an unconditional guarantee issued by a bank or surety;
- (b) an irrevocable letter of credit; or
- (c) a cashier's or certified check;

from a reputable source from an eligible country. If the unconditional guarantee is issued by an insurance company or a bonding company located outside the Employer's Country, the issuer shall have a correspondent financial institution located in the Employer's Country to make it enforceable. In the case of a bank guarantee, the bid security shall be submitted either using the Bid Security Form included in Section IV, Bidding Forms or in another substantially similar format approved by the Employer prior to bid submission. In either case, the form must include the complete name of the Bidder. The bid security shall be valid for twenty-eight days (28) beyond the original validity period of the bid, or beyond any period of extension if requested under **ITB** 18.2.

19.4 Pursuant to the option stipulated at **ITB** 19.1, any bid not accompanied by a substantially responsive bid security or Bid-Securing Declaration shall be rejected by the Employer as non-responsive.

19.5 If a bid security is specified pursuant to **ITB** 19.1, the bid security of unsuccessful Bidders shall be returned as promptly as possible upon the successful Bidder's furnishing of the performance security pursuant to **ITB** 38.

19.6 The bid security of the successful Bidder shall be returned as promptly as possible once the successful Bidder has signed the Contract and furnished the required performance security.

19.7 The bid security may be forfeited or the Bid-Securing Declaration executed:

- (a) if a Bidder withdraws its bid during the period of bid validity specified by the Bidder in the Letter of Bid or

- (b) if the successful Bidder fails to:
  - (i) sign the Contract in accordance with **ITB** 37; or
  - (ii) furnish a performance security in accordance with **ITB** 38.

19.8 The Bid Security or the Bid Securing Declaration of a JVCA shall be in the name of the JVCA that submits the bid. If the JVCA has not been legally constituted into a legally enforceable JVCA at the time of bidding, the Bid Security or the Bid Securing Declaration shall be in the names of all future partners as named in the letter of intent referred to in **ITB** 4.1.

19.9 If a Bid-Securing Declaration is executed in accordance with **ITB** 19.7, the Employer will declare the Bidder ineligible to be awarded a contract by the Employer for the period of time stated in the Form of Bid-Securing Declaration.

## **20. Format and Signing of Bid**

20.1 The Bidder shall prepare one original of the documents comprising the bid as described in **ITB** 11 and clearly mark it "ORIGINAL." In addition, the Bidder shall submit copies of the bid, in the number specified in the **BDS** and clearly mark them "COPY." In the event of any discrepancy between the original and the copies, the original shall prevail.

20.2 The original and all copies of the bid shall be typed or written in indelible ink and shall be signed by a person duly authorized to sign on behalf of the Bidder. This authorization shall consist of a written confirmation as specified in the **BDS** and shall be attached to the bid. The name and position held by each person signing the authorization must be typed or printed below the signature. All pages of the bid where entries have been made shall be signed or initialled by the person signing the bid.

20.3 A bid submitted by a JVCA shall comply with the following requirements:

- (a) Unless not required in accordance with **ITB** 4.1 (a), be signed so as to be legally binding on all partners and
- (b) Include the Representative's authorization referred to in **ITB** 4.1 (b), consisting of a power of attorney signed by those legally authorized to sign on behalf of the JVCA.

20.4 Any amendments, interlineations, erasures, or overwriting shall be valid only if they are signed or initialled by the person signing the bid.

## D. Submission and Opening of Bids

### 21. Submission, Sealing and Marking of Bids

21.1 Bidders may always submit their bids by mail or by hand. If so specified in the **BDS**, bidders shall have the option of submitting their bids electronically. Procedures for submission, sealing and marking are as follows:

(a) Bidders submitting bids by mail or by hand shall enclose the original and copies of the Bid in separate sealed envelopes. If so permitted in accordance with **ITB 13**, alternative proposals, and copies thereof, shall also be placed in separate envelopes. The envelopes shall be duly marked as “ORIGINAL,” “ALTERNATIVE,” “ORIGINAL COPY,” and “ALTERNATIVE COPY” These envelopes shall then be enclosed in one single package. The rest of the procedure shall be in accordance with **ITB 21.2** and **21.3**.

(b) Bidders submitting bids electronically shall follow the electronic bid submission procedures specified in the **BDS**.

21.2 The inner and outer envelopes shall:

(a) bear the name and address of the Bidder;

(b) be addressed to the Employer in accordance with **ITB 22.1**;

(c) bear the specific identification of this bidding process pursuant to **ITB 1.1**; and

(d) bear a warning not to open before the time and date for bid opening

21.3 If envelopes and packages are not sealed and marked as required, the Employer will assume no responsibility for the misplacement or premature opening of the bid.

### 22. Deadline for Submission of Bids

22.1 Bids must be received by the Employer at the address and no later than the date and time indicated in the **BDS**.

22.2 The Employer may, at its discretion, extend the deadline for the submission of bids by amending the Bidding Document in accordance with **ITB 8**, in which case all rights and obligations of the Employer and Bidders previously subject to the deadline shall thereafter be subject to the deadline as extended.

### 23. Late Bids

23.1 The Employer shall not consider any bid that arrives after the deadline for submission of bids, in accordance with **ITB 22**. Any bid received by the Employer after the deadline for submission of bids shall be declared late, rejected, and returned unopened to the

Bidder.

**24. Withdrawal, Substitution, and Modification of Bids**

24.1 A Bidder may withdraw, substitute, or modify its bid after it has been submitted by sending a written notice, duly signed by an authorized representative, and shall include a copy of the authorization in accordance with **ITB 20.2.**, (except that withdrawal notices do not require copies). The corresponding substitution or modification of the bid must accompany the respective written notice. All notices must be:

- (a) prepared and submitted in accordance with **ITB 20** and **ITB 21** (except that withdrawals notices do not require copies), and in addition, the respective envelopes shall be clearly marked “WITHDRAWAL,” “SUBSTITUTION,” “MODIFICATION;” and
- (b) received by the Employer prior to the deadline prescribed for submission of bids, in accordance with **ITB 22**.

24.2 Bids requested to be withdrawn in accordance with **ITB 24.1** shall be returned unopened to the Bidders.

24.3 No bid may be withdrawn, substituted, or modified in the interval between the deadline for submission of bids and the expiration of the period of bid validity specified by the Bidder on the Letter of Bid or any extension thereof.

**25. Bid Opening**

25.1 The Employer shall conduct the bid opening in public, in the presence of Bidders` designated representatives and anyone who choose to attend, and at the address, date and time specified in the **BDS**. Any specific electronic bid opening procedures required if electronic bidding is permitted in accordance with **ITB 21.1**, shall be as specified in the **BDS**.

25.2 First, envelopes marked “Withdrawal” shall be opened and read out and the envelope with the corresponding bid shall not be opened, but returned to the Bidder. No bid withdrawal shall be permitted unless the corresponding withdrawal notice contains a valid authorization to request the withdrawal and is read out at bid opening. Next, envelopes marked “Substitution” shall be opened and read out and exchanged with the corresponding bid being substituted, and the substituted bid shall not be opened, but returned to the Bidder. No bid substitution shall be permitted unless the corresponding substitution notice contains a valid authorization to request the substitution and is read out at bid opening. Envelopes marked “Modification” shall be opened and read out with the corresponding bid. No bid modification shall be permitted unless the corresponding modification notice contains a valid authorization to request the modification and is read out at bid opening. Only bids that are opened and read out at bid opening shall be considered

further.

- 25.3 The Employer shall open all other envelopes one at a time and read out: the name of the Bidder, the Bid Price(s), any discounts and their application methodology, alternative bids, the presence or absence of a bid security or Bid-Securing Declaration; and any other details as the Employer may consider appropriate. Only discounts and alternative bids read out at bid opening shall be considered for evaluation. No bid shall be rejected at bid opening except for late bids, in accordance with **ITB 23.1**.
- 25.4 The Employer shall prepare a record of the bid opening that shall include, as a minimum: the name of the Bidder and whether there is a withdrawal, substitution, or modification; the Bid Price, per lot if applicable, including any discounts and alternative proposals; and the presence or absence of a bid security or a Bid-Securing Declaration. The Bidders' representatives who are present shall be requested to sign the record. The omission of a Bidder's signature on the record shall not invalidate the contents and effect of the record. A copy of the record shall be distributed to all Bidders who submitted bids in time, and posted online when electronic bidding is permitted.

### **E. Examination of Bids**

- 26. Confidentiality**
- 26.1 Information relating to the evaluation of bids shall not be disclosed to Bidders or any other persons not officially concerned with such process until information on Contract award is communicated to all Bidders.
- 26.2 Any attempt by a Bidder to influence improperly the Employer in the evaluation of the bids or Contract award decisions may result in the rejection of its bid.
- 26.3 Notwithstanding **ITB 26.1**, from the time of bid opening to the time of Contract award, if any Bidder wishes to contact the Employer on any matter related to the bidding process, it should do so in writing.

- 27. Clarification of Bids**
- 27.1 To assist in the examination, evaluation, and comparison of the bids, and qualification of the Bidders, the Employer may, at its discretion, ask any Bidder for a clarification of its bid, allowing a reasonable time for response. Any clarification submitted by a Bidder that is not in response to a request by the Employer shall not be considered. The Employer's request for clarification and the response shall be in writing. No change in the prices or substance of the bid shall be sought, offered, or permitted, except to confirm the correction of arithmetic errors discovered by the Employer in the evaluation of the bids, in accordance with **ITB 29**.
- 27.2 If a Bidder does not provide clarifications of its bid by the date and time set in the Employer's request for clarification, its bid may be rejected.
- 28. Determination of Responsiveness**
- 28.1 The Employer's determination of a bid's responsiveness is to be based on the contents of the bid itself, as defined in **ITB 11**.
- 28.2 A substantially responsive bid is one that meets the requirements of the Bidding Document without material deviation, reservation, or omission.
- (a) "Deviation" is a departure from the requirements specified in the Bidding Document;
- (b) "Reservation" is the setting of limiting conditions or withholding from complete acceptance of the requirements specified in the Bidding Document; and
- (c) "Omission" is the failure to submit part or all of the information or documentation required in the Bidding Document.
- 28.3 A material deviation, reservation, or omission is one that,
- (a) if accepted, would:
- (i) affect in any substantial way the scope, quality, or performance of the Schedule of Requirements as specified in Section VI; or
- (ii) limit in any substantial way, inconsistent with the Bidding Document, the Employer's rights or the Bidder's obligations under the proposed Contract; or
- (b) if rectified, would unfairly affect the competitive position of other Bidders presenting substantially responsive bids.

- 28.4 The Employer shall examine the technical aspects of the bid in particular, to confirm that all requirements of Section VI have been met without any material deviation, reservation, or omission.
- 28.5 If a bid is not substantially responsive to the requirements of the Bidding Document, it shall be rejected by the Employer and may not subsequently be made responsive by correction of the material deviation, reservation, or omission.
- 28.6 Provided that a bid is substantially responsive, the Employer may waive any quantifiable nonconformity in the bid that does not constitute a material deviation, reservation or omission.
- 28.7 Provided that a bid is substantially responsive, the Employer may request that the Bidder submit the necessary information or documentation, within a reasonable period of time, to rectify nonmaterial nonconformities in the bid related to documentation requirements. Requesting information or documentation on such nonconformities shall not be related to any aspect of the price of the bid. Failure of the Bidder to comply with the request may result in the rejection of its bid.
- 28.8 Provided that a bid is substantially responsive, the Employer shall rectify quantifiable nonmaterial nonconformities related to the Bid Price. To this effect, the Bid Price shall be adjusted, for comparison purposes only, to reflect the price of the non-conforming item or component. The adjustment shall be made using the methodology indicated in Section III, Evaluation and Qualification Criteria.

## **F. Bid Evaluation and Comparison**

### **29. Correction of Arithmetical Errors**

- 29.1 The Employer shall use the criteria and methodologies indicated in Section III, Evaluation and Qualification Criteria. No other evaluation criteria or methodologies shall be permitted
- 29.2 Provided that the bid is substantially responsive, the Employer shall correct arithmetical errors as indicated in Section III, Evaluation and Qualification Criteria
- 29.3 If a Bidder does not accept the correction of errors, its bid shall be declared non-responsive and its Bid Security shall be forfeited or the Bid-Securing Declaration executed.

### **30. Conversion to Single Currency**

- 30.1 For evaluation and comparison purposes, the currency(ies) of the bid shall be converted into a single currency as specified in Section III, Evaluation and Qualification Criteria.

### **31. Bid Adjustments**

- 31.1 For evaluation and comparison purposes the Employer shall adjust the bid prices using the criteria and methodology specified in

## Section III, Evaluation and Qualification Criteria.

- 31.2 Unless otherwise specified in the **BDS**, no margin of domestic or regional preference shall apply. If a margin of preference applies, the application methodology shall be as specified in Section III, Evaluation and Qualification Criteria, and in accordance with the provisions stipulated in the Bank's **Rules and Procedures for Procurement of Goods and Works**.
- 31.3 If in the opinion of the Employer the bid which results in the lowest Evaluated Bid, is seriously unbalanced or front loaded or substantially below the Employer's estimates, the Employer may require the Bidder to produce detailed price analyses for any or all items of the Bill of Quantities, to demonstrate the internal consistency of those prices with the methods and schedule proposed. After evaluation of the price analyses, taking into consideration the schedule of estimated Contract payments, the Employer may require that the amount of the performance security be increased at the expense of the Bidder to a level sufficient to protect the Employer against financial loss in the event of default of the successful Bidder under the Contract.

**32. Qualification of the Bidder**

- 32.1 The Employer shall determine to its satisfaction whether the Bidder that is selected as having submitted the lowest evaluated and substantially responsive bid meets the qualifying criteria specified in Section III, Evaluation and Qualification Criteria.
- 32.2 The determination shall be based upon an examination of the documentary evidence of the Bidder's qualifications submitted by the Bidder, pursuant to **ITB 16**.
- 32.3 An affirmative determination shall be a prerequisite for award of the Contract to the Bidder. A negative determination shall result in disqualification of the bid, in which event the Employer shall proceed to the next lowest evaluated bid to make a similar determination of that Bidder's qualifications to perform satisfactorily.
- 32.4 The capabilities of the manufacturers and subcontractors proposed in its Bid to be used by the lowest evaluated Bidder for identified major items of the Requirements will also be evaluated for acceptability in accordance with the criteria and methodologies defined in Section III, Evaluation and Qualification Criteria. Their participation should be confirmed with a letter of intent between the parties, as needed. Should a manufacturer or subcontractor be determined to be unacceptable, the Bid will not be rejected, but the Bidder will be required to substitute an acceptable manufacturer or



subcontractor without any change to the bid price.

- 33. Comparison of Bid** 33.1 Subject to **ITB** 29, 30 and 31, the Employer shall compare all substantially responsive bids to determine the lowest evaluated bid.
- 34. Employer's Right to Accept Any Bid, and to Reject Any or All Bids** 34.1 The Employer reserves the right to accept or reject any bid, and to annul the bidding process and reject all bids at any time prior to contract award, without thereby incurring any liability to Bidders. In case of annulment, all bids submitted and specifically, bid securities, shall be promptly returned to the Bidders.

### **G. Award of Contract**

- 35. Award Criteria** 35.1 Subject to **ITB** 34.1, the Employer shall award the Contract to the Bidder whose offer has been determined to be the lowest evaluated bid and is substantially responsive to the Bidding Document, provided further that the Bidder is determined to be qualified to perform the Contract satisfactorily.
- 36. Notification of Award** 36.1 Prior to the expiration of the period of bid validity, the Employer shall notify the successful Bidder, in writing, that its bid has been accepted. The notification letter (hereinafter and in the Conditions of Contract and Contract Forms called the "Letter of Acceptance") shall specify the sum that the Employer will pay the Contractor in consideration of the execution and completion of the Works (hereinafter and in the Contract Forms called "the Contract Price").
- 36.2 Until a formal contract is prepared and executed, the notification of award shall constitute a binding Contract.
- 36.3 At the same time, the Employer shall also notify all other Bidders of the results of the bidding process, and shall publish in **UNDB online** and at the **Bank's website** ([www.afdb.org](http://www.afdb.org)), the results identifying the bid and lot numbers and the following information: (i) name of each Bidder who submitted a Bid; (ii) bid prices as read out at bid opening; (iii) name and evaluated prices of each Bid that was evaluated; (iv) name of bidders whose bids were rejected and the reasons for their rejection; and (v) name of the winning Bidder, and the price it offered, as well as the duration and summary scope of the contract awarded. After publication of the award, unsuccessful bidders may request in writing to the Employer for a debriefing seeking explanations on the grounds on which their bids were not selected. The Employer shall promptly respond in writing to any unsuccessful Bidder who, after Publication of contract award, requests a debriefing.
- 37. Signing of Contract** 37.1 Promptly upon notification, the Employer shall send the successful Bidder the Contract Agreement.

- 37.2 Within twenty-eight (28) days of receipt of the Contract Agreement, the successful Bidder shall sign, date, and return it to the Employer.
- 37.3 Upon the successful Bidder's furnishing of the signed Contract Agreement and Performance Security pursuant to **ITB** 38, the Employer will discharge its Bid Security, pursuant to **ITB** 19.
- 37.4 Notwithstanding **ITB** 37.2 above, in case signing of the Contract Agreement is prevented by any export restrictions attributable to the Employer, to the country of the Employer, or to the use of the products/goods, systems or services to be supplied, where such export restrictions arise from trade regulations from a country supplying those products/goods, systems or services, the Bidder shall not be bound by its bid, always provided, however, that the Bidder can demonstrate to the satisfaction of the Employer and of the Bank that signing of the Contract Agreement has not been prevented by any lack of diligence on the part of the Bidder in completing any formalities, including applying for permits, authorizations and licenses necessary for the export of the products/goods, systems or services under the terms of the Contract Agreement.

### **38. Performance Security**

- 38.1 Within twenty-eight (28) days of the receipt of notification of award from the Employer, the successful Bidder shall furnish the performance security in accordance with the conditions of contract, subject to **ITB** 31.3, using for that purpose the Performance Security Form included in Section IX, Contract Forms, or another form acceptable to the Employer. If the performance security furnished by the successful Bidder is in the form of a bond, it shall be issued by a bonding or insurance company that has been determined by the successful Bidder to be acceptable to the Employer. A foreign institution providing a bond shall have a correspondent financial institution located in the Employer's Country.
- 38.2 Failure of the successful Bidder to submit the above-mentioned Performance Security or sign the Contract shall constitute sufficient grounds for the annulment of the award and forfeiture of the bid security, or execution of the Bid-Securing Declaration. In that event the Employer may award the Contract to the next lowest evaluated Bidder whose offer is substantially responsive and is determined by the Employer to be qualified to perform the Contract satisfactorily.

<b>Section II. Bid Data Sheet</b>
-----------------------------------

<b>A. General</b>	
<b>ITB 1.1</b>	The number of the Invitation for Bids is: <b><i>KFS/GZDSP II/002/2024-2025</i></b>
<b>ITB 1.1</b>	The Employer is: <b><i>Kenya Forest Service</i></b>
<b>ITB 1.1</b>	<p>The name of the bidding process is: <b><i>Open Competitive Bidding with national advertising</i></b></p> <p>The identification number of the bidding process is:</p> <p style="margin-left: 20px;"><b>KFS/GZDSP II/002/2024-2025</b></p> <p>The number and identification for this bidding process is:</p> <p style="margin-left: 20px;"><b>KFS/GZDSP II/002/2024-2025;-</b></p> <p style="margin-left: 20px;"><b>CONSTRUCTION OF SOLAR-POWERED ELECTRIC PERIMETER FENCE FOR KAPCHUMBE FOREST BLOCK CHEPALUNGU FOREST STATION IN BOMET COUNTY</b></p>
<b>ITB 2.1</b>	The Borrower is: <b>Government of Kenya</b>
<b>ITB 2.1</b>	The specific Bank financing institution is: <b>ADF</b>
<b>ITB 2.1</b>	The name of the Project is: <b>Green Zones Development Support Project Phase II</b>
<b>ITB 4.1(a)</b>	The individuals or firms in a joint venture, consortium or association <b>shall be</b> jointly and severally liable.
<b>B. Contents of Bidding Document</b>	
<b>ITB 7.1</b>	<p>For <b><u>clarification purposes</u></b> only, the Employer's address is:</p> <p>Attention: <b>Chief Conservator of Forest, Kenya Forest Service</b></p> <p>Street Address: <b>Karura, off-Kiambu Road</b></p> <p>Floor/Room number: <b>Office Reception</b></p> <p>City: <b>Nairobi</b></p> <p>ZIP Code: <b>P.O. Box 30513-00100</b></p> <p>Country: <b>Nairobi</b></p>

	<p>Telephone: +254 20 3754905  Facsimile number: +254 20 3764249  Electronic mail address: <b>director@kenyaforestservice.org</b></p> <p>Requests for clarifications should be received by the Employer no later than <b>(7) Seven days</b> prior to the deadline for submission of Bids.</p>
<b>ITB 7.4</b>	<p>A Pre-Bid meeting <b>shall not</b> take place.</p> <p>A Site Visit conducted by the Employer <b>shall</b> organized.</p> <p>If a Site Visit will take place, it will be at the following date, time and place:  Date: <b>25th February 2025</b>  Time: <b>9.00am</b>  Place: <b>County Forest Conservator Bomet County Office.</b></p>
<b>C. Preparation of Bids</b>	
<b>ITB 10.1</b>	The language of the bid is: <b>ENGLISH</b>
<b>ITB 11.1 (h)</b>	<p>The Bidder must provide the following Documentary Evidence to establish the conformity of the Technical Proposal with the Bidding Document:</p> <ol style="list-style-type: none"> <li>1. List of equipment proposed for the works (<i>Attach proof or evidence of ownership/Lease agreements</i>)</li> <li>2. List of proposed personnel, signed CV's and clear proposed positions/tasks for each</li> <li>3. Detailed program of works and works methodology -The Contractor to prepare a detailed program of works (in MS Projects or applicable equivalent) showing clearly the Contractor proposed duration to carry out the works and detailed methodology for the successful bidder, this shall be revised within 14 days from commencement of project.</li> <li>4. Detailed Occupation, Safety and Health plan</li> <li>5. Duly Completed schedules as provided in Section IV, Bidding forms</li> <li>6. Written confirmation authorising the signatory of the Bid to commit the bidder, in accordance to ITB 20.2</li> </ol>
<b>ITB 11.1 (j)</b>	<p>The Bidder shall submit with its bid the following <b>mandatory</b> documents:</p> <ol style="list-style-type: none"> <li>1. Valid copy of Registration Certificate /Certificate of Incorporation.</li> <li>2. Valid copy of the business permit with physical location.</li> <li>3. Valid tax compliance certificate at the time of submission</li> <li>4. PIN Certificate with VAT obligation</li> <li>5. Copy of a valid CR 12 not older than 6 months and for sole Proprietors</li> </ol>

	<p>(copies of National Identity Cards for Business Registration and sole proprietors)</p> <ol style="list-style-type: none"> <li>6. Must attach an Original bid security of <b>2% of the bid offer price</b> valid for 154 days from the date of tender closing/opening issued by a recognized bank or an authorized insurance firm</li> <li>7. Provide Audited accounts for the last three years (Years 2022,2023,2024)</li> <li>8. Dully filled signed and stamped Addendum(s)/Clarification(s) issued must be attached(Where Applicable).</li> <li>9. Attach a Valid NCA 5 or above Certificate for Buildings/Civil works (incase of a joint venture at least one partner of the JV should have certification)</li> <li>10. Attach a Valid NCA 5 or above for Electrical Works (incase of a joint venture at least one partner of the JV should have certification)</li> <li>11. Attach original Site Visit Certificate (Duly signed and stamped by employer's representative)</li> <li>12. For Joint Venture the Lead Partner should have at least one valid NCA Certification in either Civil works/Buildings or Electrical Works</li> <li>13. Attach a Valid annual Practicing license for NCA 5 or above for Buildings</li> <li>14. Attach a Valid annual Practicing license for NCA 5 or above for Electrical Works</li> <li>15. Power of attorney signed and stamped by an advocate</li> <li>16. Dully Completed , signed and stamped Confidential Business Questionnaire</li> <li>17. Duly Completed, signed and stamped Letter of Bid</li> <li>18. Duly Completed, signed and stamped Price schedules</li> <li>19. Provide detailed brochures /catalogues for the following; - <ul style="list-style-type: none"> <li>• Solar panel</li> <li>• Energizer machine</li> <li>• Charge regulator/controller</li> <li>• Lightning arrestors</li> <li>• Flood gate controller</li> <li>• Solar battery</li> </ul> </li> <li>20. Tender document must be properly bound and all pages sequential serialized or paginated with a table of contents.</li> </ol>
<b>ITB 13.1</b>	Alternative bids: <b>not permitted</b>
<b>ITB 13.2</b>	Alternatives to the Times for Completion <b>shall not</b> be permitted.
<b>ITB 13.4</b>	Alternative technical solutions shall be permitted for the following parts of the Works, as further detailed in the Specification: <b>none</b>

<b>ITB 14.2</b>	Prices <b>shall be</b> fixed.
<b>ITB 14.6</b>	The prices quoted by the Bidder <b>shall not be</b> subject to adjustment during the performance of the Contract.
<b>ITB 15.1</b>	The currency(ies) of the bid and the payment currency(ies) shall be as described below: The currency of the bid and payment shall be: <b>Kenya Shillings</b>
<b>ITB 18.1</b>	The bid validity period shall be <b>120</b> days.
<b>ITB 19.1</b>	The Bidder shall furnish a bid security, in the amount of <b>2% of the bid offer price</b> in a freely convertible currency; the security shall be in the form of a <b>bank guarantee</b> and must be from a reputable bank valid for <b>154 days</b> from the date of tender opening. <b>The beneficiary of the security shall be the Chief Conservator of Forests, P. O. Box 30513 – 00100 Nairobi.</b> A guarantee from a foreign bank shall also be certified by a local reputable bank prior to submission.
<b>ITB 20.1</b>	In addition to the original of the Bid, the number of copies is: <b>1</b>
<b>ITB 20.2</b>	The written confirmation of authorization to sign on behalf of the Bidder shall <b>Power of Attorney</b>  (a) The name and description of the documentation required to demonstrate the authority of the signatory to sign the Bid such as a Power of Attorney; and  (b) In the case of Bids submitted by an existing or intended JVCA an undertaking signed by all parties (i) stating that all parties shall be jointly and severally liable, if so required in accordance with <b>ITB 4.1(a)</b> , and (ii) nominating a Representative who shall have the authority to conduct all business for and on behalf of any and all the parties of the JVCA during the bidding process and, in the event the JV is awarded the Contract, during contract execution.
<b>D. Submission and Opening of Bids</b>	
<b>ITB 21.1</b>	Bidders <b>shall not</b> have the option of submitting their bids electronically.
<b>ITB 21.1 (b)</b>	The electronic bidding submission procedures shall be: <b>N/A</b>

<b>ITB 22.1</b>	<p>For <b>bid submission purposes</b> only, the Employer's address is :</p> <p>Attention: <b>Chief Conservator of Forests, Kenya Forest Service</b>  Street Address: <b>Karura, Off Kiambu Road</b>  Floor/Room number: <b>KFS Headquarters reception</b>  City: <b>Nairobi</b>  ZIP Code: <b>P.O. Box 30513 – 00100</b>  Country: <b>Kenya</b></p> <p><b>The deadline for bid submission is:</b>  Date: <b>7<sup>th</sup> March 2025</b>  Time: <b>11.00 am</b></p>
<b>ITB 25.1</b>	<p><b>The bid opening shall take place at:</b>  Street Address: <b>Karura, Off Kiambu road</b>  Floor/Room number: <b>KFS Canteen Boardroom, KFS Headquarters</b>  City : <b>Nairobi</b>  Country: <b>Kenya</b>  Date: <b>7<sup>th</sup> March 2025</b>  Time: <b>11.05 am East African Standard Time</b></p>
<b>ITB 25.1</b>	The electronic bid opening procedures shall be: <b>N/A</b>
<b>F. Bid Evaluation and Comparison</b>	
<b>ITB 31.2</b>	<p>A margin of domestic or regional preference <b>shall not</b> apply.  If a margin of domestic or regional preference applies, the application methodology shall be: <b>N/A</b></p>

## **Section III. Evaluation and Qualification Criteria**

This Section contains all the criteria that the Employer shall use to evaluate bids and qualify Bidders. In accordance with **ITB 28** and **ITB 32**, no other factors, methods or criteria shall be used. The Bidder shall provide all the information requested in the forms included in Section IV, Bidding Forms.

### **1. Evaluation Criteria and Methodology**

#### **1.1 Alternative Proposal (If permitted in accordance with ITB 13.1)**

Technical Alternative: **N/A**

Alternative Time for Completion: **N/A**

#### **1.2 Correction of Arithmetical Errors (In accordance with ITB 29.1)**

- (a) Where there are errors between the total of the amounts given under the column for the price breakdown and the amount given under the Total Price, the former shall prevail and the latter will be corrected accordingly
- (b) If there is a discrepancy between the unit price and the total price that is obtained by multiplying the unit price and quantity, the unit price shall prevail and the total price shall be corrected, unless in the opinion of the Employer there is an obvious misplacement of the decimal point in the unit price, in which case the total price as quoted shall govern and the unit price shall be corrected;
- (c) If there is an error in a total corresponding to the addition or subtraction of subtotals, the subtotals shall prevail and the total shall be corrected; and
- (d) If there is a discrepancy between words and figures, the amount in words shall prevail, unless the amount expressed in words is related to an arithmetic error, in which case the amount in figures shall prevail subject to (a) and (b) above.

#### **1.3 Conversion to a Single Currency (In accordance with ITB 30)**

**Not applicable**

#### **1.4 Discounts (In accordance with ITB 14.5)**

The Employer will adjust the Bid Price, using the methodology prescribed by the Bidder in its Letter of Bid, to take account of the Discounts offered by the Bidder in its Letter of Bid, as read out at the Bid Opening.



**Quantifiable Nonmaterial Nonconformities (In accordance with ITB 28.8)**

The adjustment shall be made using the following methodology: N/A

**1.6 Margin of Domestic or Regional Preference (If permitted in accordance with ITB 31.2)**

N/A

**1.7 Any other Criteria or Methodology**

N/A

## 2. Qualification Criteria

N.B.: This SBD for Procurement of Small Works assumes that no Prequalification has taken place before bidding. However, if a Prequalification process is undertaken, then the Qualification Criteria stipulated in this Section III, Evaluation and Qualification Criteria must be updated to ensure that the Bidder and any Subcontractors shall meet or continue to meet the Criteria used at the time of Prequalification.

<b>2</b>	<b>Qualification (Without Prequalification)</b>
<b>2.1</b>	Eligibility (TABLE)
<b>2.2</b>	Historical Contract Non-Performance (TABLE)
<b>2.3</b>	Financial Situation (TABLE)
<b>2.4</b>	Experience (TABLE)
<b>2.5</b>	Personnel (TABLE)
<b>2.6</b>	Equipment (TABLE)

## 2. Qualification Tables (Without Prequalification)

Factor	2.1 Eligibility					
Sub-Factor	Criteria					Documentation Required
	Requirement	Single Entity	Bidder			
			Joint Venture, Consortium or Association			
			All partners combined	Each partner	At least one partner	
2.1.1 Nationality	Nationality in accordance with <b>ITB</b> 4.2.	N/A	N/A	N/A	N / A	Form ELI –1.1 and 1.2, with attachments
2.1.2 Conflict of Interest	No- conflicts of interests as described in <b>ITB</b> 4.3.	Must meet requirement	Existing or intended JVCA must meet requirement	Must meet requirement	N / A	Letter of Bid
2.1.3 Bank Ineligibility	Not having been declared ineligible by the Bank as described in <b>ITB</b> 4.4.	Must meet requirement	Existing JVCA must meet requirement	Must meet requirement	N / A	Letter of Bid
2.1.4 Government Owned Entity	Compliance with conditions of <b>ITB</b> 4.5	Must meet requirement	Must meet requirement	Must meet requirement	N / A	Form ELI –1.1 and 1.2, with attachments
2.1.5 Ineligibility based on a United Nations resolution or Borrower’s country law	Not having been excluded as a result of the Borrower’s country laws or official regulations, or by an act of compliance with UN Security Council resolution, in accordance with <b>ITB</b> 4.8	Must meet requirement	Existing JVCA must meet requirement	Must meet requirement	N / A	Letter of Bid

Factor	2.2 Historical Contract Non-Performance					
Sub-Factor	Criteria					Documentation Required
	Requirement	Bidder				
		Single Entity	Joint Venture, Consortium or Association			
All partners combined			Each partner	At least one partner		
2.2.1 History of non-performing contracts	Non-performance of a contract did not occur within the <b>last three (3) years</b> prior to the deadline for application submission, based on all information on fully settled disputes or litigation. A fully settled dispute or litigation is one that has been resolved in accordance with the Dispute Resolution Mechanism under the respective contract, and where all appeal instances available to the bidder have been exhausted.	Must meet requirement by itself or as partner to past or existing JVCA	N / A	Must meet requirement by itself or as partner to past or existing JVCA	N / A	Form CON - 2
2.2.2 Failure to Sign Contract	Not being under execution of Bid-Securing Declaration pursuant to <b>ITB</b> 4.6 for 5 years	Must meet requirement	N / A	Must meet requirement by itself or as partner to a JVCA	N / A	Letter of Bid
2.2.3 Pending Litigation	All pending litigation shall in total not represent more than fifty percent (50%) of the Bidder's net worth and shall be treated as resolved against the Bidder	Must meet requirement by itself or as partner to past or existing JVCA	N / A	Must meet requirement by itself or as partner to past or existing JVCA	N / A	Form CON – 2

Factor	2.3 Financial Situation					
Sub-Factor	Criteria					Documentation Required
	Requirement	Bidder				
		Single Entity	Joint Venture, Consortium or Association			
			All partners combined	Each partner	At least one partner	
2.3.1 Historical Financial Performance	Submission of audited balance sheets or if not required by the law of the bidder’s country, other financial statements acceptable to the Employer, for the last three [3] years to demonstrate the current soundness of the bidders financial position and its prospective long term profitability.  (a) (criterion 1): <b>Current ratio= Liquid Asset/Liquidity Liability &gt;1</b>  (b) (criterion 2): Debt Ratio = Total Debt/Total Asset <1	Must meet requirement	N / A	Must meet requirement	N / A	Form FIN – 3.1 with attachments
2.3.2. Average Annual Turnover	Minimum average annual turnover of <b>KES 50 million</b> for, calculated as total certified payments received for contracts in progress or completed, within the last 3 years	Must meet requirement	Must meet requirement	Must meet Thirty percent (30%) of the requirement	Must meet fifty percent (50%) of the requirement	Form FIN –3.2

Factor	2.3 Financial Situation					
Sub-Factor	Criteria					Documentation Required
	Requirement	Bidder				
		Single Entity	Joint Venture, Consortium or Association			
			All partners combined	Each partner	At least one partner	
2.3.3. Financial Resources	<p>The Bidder must demonstrate access to, or availability of, financial resources such as liquid assets, unencumbered real assets, lines of credit, and other financial means, other than any contractual advance payments to meet:</p> <p>(i) the following cash-flow requirement: <b>ksh 15,000,000</b> and</p> <p>(ii) the overall cash flow requirements for this contract and its current commitments.</p>	Must meet requirement	Must meet requirement	Must meet Thirty percent (30%) of the requirement	Must meet fifty percent (50%) of the requirement	<p>Form FIN –3.3</p> <p>+</p> <p>Form CCC</p>

Factor	2.4 Experience					
Sub-Factor	Criteria					Documentation Required
	Requirement	Bidder				
		Single Entity	Joint Venture, Consortium or Association			
			All partners combined	Each partner	At least one partner	
2.4.1 General Experience	Experience under contracts in the role of contractor, subcontractor, or management contractor for at least the last five [5] years prior to the applications submission deadline, and with activity in at least nine (9) months in each year.	Must meet requirement	N / A	Must meet requirement	N / A	Form EXP-4.1
2.4.2 Specific Experience	Participation as contractor, management contractor, or subcontractor <b>in carrying out purely solar powered electric fence excluding composite fence(Masonry/Electric) fences with a minimum length of 20Km</b> in at least five (5) contracts within the last five (5) years, each with a value of at least <b>Ksh Fifty million (Ksh 50,000,000).Completion certificates for each contract should be attached with clear employer name and contact details.</b>	Must meet requirement	Must meet requirements for all characteristics	N / A	Must meet requirement for one characteristic	Form EXP 2.4.2(a)
2.4.2 Specific Experience	b) For the above or other contracts executed during the period stipulated in 2.4.2(a) above, a minimum experience in the following key activities: Construction of buildings	Must meet requirements	Must meet requirements	N / A	Must meet requirements	Form EXP-2.4.2(b)

## 2.5 Personnel

The Bidder must demonstrate that it will have the personnel for the key positions that meet the following requirements:

No.	Position	Qualification
1	Project Manager	Degree in Civil Engineering/Building Construction from a recognized university (Attach University certificate, Membership with EBK and Valid annual practicing license). Attach CV & certificates with experience of not less than five (5) years
2	Site agent	Diploma in any of the following fields;- (Civil engineering, Electrical engineering, Building technology). Attach CV & certificates with a total work experience of eight (8) years
3	Foreman	Diploma in Building and Construction/ Civil Engineering. Attach CV & Certificates with a total work experience of 10 years and 5 years in similar work
4	Surveyor	Diploma in Land Survey. Attach CV & Certificates with a total work experience of 5 years
5	Artisans <ul style="list-style-type: none"> <li>• Mason</li> <li>• Carpenter</li> <li>• Plumber</li> <li>• Electrician</li> </ul>	Certificate in Masonry, Plumbing, Electrical wire man, Carpentry & joinery

The Bidder shall provide details of the proposed personnel and their experience records in the relevant Forms included in Section IV, Bidding Forms.

## 2.6 Equipment

The Bidder must demonstrate that it will have access to the key Contractor's equipment listed hereafter:

No.	Equipment Type and Characteristics	Minimum Number required
1	Lorry 7 tonner and above	1
2	Concrete mixer	1
3	Poker Vibrator	1
4	Mechanical compacting machine	1
5	Pick-up truck	1
6	Soil Auger	1

The Bidder shall provide further details of proposed items of equipment using the relevant Form in Section IV.



## Section IV. Bidding Forms

### Table of Forms

<b>Letter of Bid.....</b>	<b>44</b>
<b>Bill of Quantities/Schedules of Prices.....</b>	<b>47</b>
<b>Schedule of Adjustment Data.....</b>	<b>48</b>
<b>Summary of Payment Currencies.....</b>	<b>49</b>
<b>Form of Bid Security (Bank Guarantee).....</b>	<b>51</b>
<b>Form of Bid Security (Bid Bond).....</b>	<b>53</b>
<b>Form of Bid-Securing Declaration.....</b>	<b>55</b>
<b>Technical Proposal .....</b>	<b>57</b>
Site Organization.....	58
Method Statement .....	59
Mobilization Schedule .....	60
Construction Schedule .....	61
Contractor's Equipment .....	62
Proposed Personnel .....	63
Resume of Proposed Personnel.....	64
Others .....	65
<b>Bidder's Qualification.....</b>	<b>66</b>
Bidder Information Sheet .....	67
Party to JVCA Information Sheet .....	68
Historical Contract Non-Performance.....	69
Current Contract Commitments / Works in Progress.....	70
Financial Situation.....	71
Average Annual Turnover.....	73
Financial Resources.....	74
General Experience .....	75
Specific Experience.....	76
Specific Experience in Key Activities.....	78

## Letter of Bid

The Bidder must prepare the Letter of Bid on stationery with its letterhead clearly showing the Bidder's complete name and address.

Date: \_\_\_\_\_  
 Bidding No.: \_\_\_\_\_  
 Invitation for Bid No.: \_\_\_\_\_

To:

We, the undersigned, declare that:

- (a) We have examined and have no reservations to the Bidding Documents, including Addenda issued in accordance with Instructions to Bidders (**ITB**) Clause 8;
- (b) We offer to execute in conformity with the Bidding Documents the following Works:  
 \_\_\_\_\_;
- (c) The total price of our Bid, excluding any discounts offered in item (d) below is:  
 \_\_\_\_\_;
- (d) The discounts offered and the methodology for their application are: \_\_\_\_\_;
- (e) Our bid shall be valid for a period of \_\_\_\_\_ [insert validity period as specified in **ITB** 18.1.] days from the date fixed for the bid submission deadline in accordance with the Bidding Documents, and it shall remain binding upon us and may be accepted at any time before the expiration of that period;
- (f) If price adjustment provisions apply, the Table(s) of Adjustment Data shall be considered part of this Bid;<sup>5</sup>
- (g) If our bid is accepted, we commit to obtain a performance security in accordance with **ITB** 38 and **GC** 5.15, for the due performance of the Contract;
- (h) Our firm, including any subcontractors or suppliers for any part of the Contract, have nationalities from eligible countries;

<sup>5</sup> Include if price adjustment provisions apply in the Contract in accordance with **PC** Clause **5.10 Price Adjustment**.

- (i) We, including any subcontractors or suppliers for any part of the contract, do not have any conflict of interest in accordance with **ITB 4.3**;
- (j) We are not participating, as a Bidder or as a subcontractor, in more than one bid in this bidding process in accordance with **ITB 4.3**, other than alternative offers submitted in accordance with **ITB 13**;
- (k) Our firm, its affiliates or subsidiaries (including any Subcontractors or Suppliers for any part of the contract), has not been declared ineligible by the Bank, or under execution of a Bid-Securing Declaration in the Employer's country, or under the Employer's country laws or official regulations, or by an act of compliance with a decision of the United Nations Security Council, in accordance with **ITB 4.4, 4.6 and 4.8**, respectively;
- (l) We are not a government owned entity / We are a government owned entity but meet the requirements of **ITB 4.5**;<sup>6</sup>
- (m) We have paid, or will pay the following commissions, gratuities, or fees with respect to the bidding process or execution of the Contract: <sup>7</sup>

Name of Recipient	Address	Reason	Amount
.....	.....	.....	.....
.....	.....	.....	.....

- (n) We undertake that, in competing for (and, if the award is made to us, in executing) the above contract, we will strictly observe the laws against fraud and corruption in force in the country of the Employer, as such laws have been listed by the Employer in the bidding documents for this contract.<sup>8</sup>
- (o) We understand that this bid, together with your written acceptance thereof included in your notification of award, shall constitute a binding contract between us, until a formal contract is prepared and executed;
- (p) We understand that you are not bound to accept the lowest evaluated bid or any other bid that you may receive; and
- (q) If awarded the contract, the person named below shall act as Contractor's Representative:  
 \_\_\_\_\_
- (r) We accept the appointment of [**Employer to insert full name and address of suggested appointee**] as the Adjudicator. / We do not accept the appointment of [**Bidder to insert name suggested by Employer**] as the Adjudicator, and propose instead that [**Bidder to**

<sup>6</sup> Use one of the two options as appropriate.

<sup>7</sup> If none has been paid or is to be paid, indicate "none".

<sup>8</sup> The Bank will accept the introduction of such undertaking at the request of the Borrowing country, provided the arrangements governing such undertaking are satisfactory to the Bank.

**insert alternative name]** be appointed as the Adjudicator, whose daily fees and biographical data are attached.<sup>9</sup>

Name: .....

In the capacity of: .....

Signed: .....

Duly authorized to  
sign the Bid for and on  
behalf of: .....

Date: .....

---

<sup>9</sup> Use one of the two options as appropriate.

**BILL OF QUANTITIES/SCHEDULES OF PRICES**

**CONSTRUCTION OF ELECTRIC PERIMETER FENCE  
FOR KAPCHUMBE FOREST BLOCK IN BOMET  
COUNTY**

BILLS OF QUANTITIES

PROJECT

PROPOSED CONSTRUCTION OF ELECTRIC PERIMETER FENCE

FOR KAPCHUMBE FOREST BLOCK IN BOMET COUNTY

KENYA FOREST SERVICE

**BILL NO. 1: PRELIMINARIES**

ITEM	DESCRIPTION	UNIT	QTY	RATE	AMOUNT
1	<i>Preliminaries</i>				
	Project Sign Board				
1.01	Allow for providing, erecting, and maintaining throughout course of the contract and afterwards clearing away of sign board as designed, specified and approved by the Project Manager	No.	1		
	Location of Site				
1.02	The site location is as follows:				
	Chepalungu Forest, Kapchumbe Block, Bomet County				
	Clearing Away				
1.03	The Contractor shall remove all temporary works, rubbish, debris and surplus materials from the site as they accumulate and upon completion of the works, remove and clear, away all plant, equipemnt rubbish, unused materials and stains and leave in clean and tidy state to the reasonable satisfaction of the Project Manager.	PC SUM	1		
	Labour Camps				
1.04	The Contractor shall be fully responsible for accommodation of his workmen throught the contrat period.	PC SUM	1		
	Security of Works etc				
1.05	The Contractors shall be entirely responsible for the security of all the works stores, materials, plant, personnel, etc. both his own and sub-contractors and must provide all necessary watching, lighting and other precaution as necessary to ensure security against theft, loss or damage and the protection of the public. Note that the contractor may need to engage armed security personnel on a full time basis.	Month s	6		
	Transport				
1.06	Allow for transport of workmen, materials, etc, to and from the site at such hours and by such routes as may be permitted by the competent authorities	month	6		
1.07	Total Carried to Summary for Preliminaries				



ITEM	DESCRIPTION	UNIT	QTY	RATE	AMOUNT
1	<i>Preliminaries</i>				
	Facilitation for Project Supervision Staff				
1.08	Provisional sum of Kshs. 1,500,000.00 (One million and Five Hundred Thousand shillings only) as facilitation for Project supervision team to attend site meetings throught the course of the project. The amount to take care of daily subsistence allowance for staff.	PS	1		
	Storage of Materials				
1.09	The contractor shall provide at his own risk and cost where directed on the site weather proof lock-up storage for materials and make good damaged or disturbed surface upon completion to the satisfaction of the PROJECT MANAGER	PC SUM	1		
	Project Site Office				
1.10	The Contractor shall provide, erect and maintain where directed on site and afterwards dismantle a temporary site office as directed by Project Manager, complete with Furniture.	NO	1		
	Samples				
1.11	The Contractor shall furnish at his own cost any samples of materials or workmanship required for the works that may be called for by the PROJECT MANAGER for his/her approval until such samples are approved by the PROJECT MANAGER and the PROJECT MANAGER may reject any materials or workmanship not in his opinion to be up to approved samples. The PROJECT MANAGER shall arrange for the testing of such materials as he may at his/her discretion deem desirable, but the testing shall be made at the expense of the Contractor and not at the expenses of the PROJECT MANAGER.	LS	1		
	Sanitation of Works				
1.12	The cntractor shall provide suitable, sufficient nd approved Sanitary facility for his workment to use throught the entire period of the contract. NO defication in open areas within the foret will be tolarated	LS	1		
1.13	Total Carried to Summary for Preliminaries				

ITEM	DESCRIPTION	UNIT	QTY	RATE	AMOUNT
1	<i>Preliminaries</i>				
	Supervision and Working Hours				
1.14	The works shall be executed under the direction and to the entire satisfaction in all respects of the PROJECT MANAGER who shall at all times during normal working hours have access to the works and to the yards and workshop of the contractor or other places where work is being prepared for the contract.	LS			
	Water and Electricity Supply for the Works				
1.15	The Contractor shall provide at his own cost all necessary water, electric power and lighting required for use in the works. The Contractor shall make his own arrangements for connection to the nearest suitable water source. He must also provide temporary tanks as required at his own cost and clear away when no longer required and make good on completion to the entire satisfaction of the PROJECT MANAGER. The Contractor shall pay all charges in connection herewith.	Item	1		
	Insurance				
1.16	The Contractor shall insure the works and workmen. No payment on account of the work executed will be made to the Contractor until he has satisfied the PROJECT MANAGER either by production of an Insurance Policy or and Insurance Certificate that the provision of the foregoing Insurance Clauses have been complied with in all respects. Thereafter the PROJECT MANAGER shall from time to time ascertain the premiums are duly paid by the Contractor who shall if called upon to do so, produce the receipted premium renewals for the PROJECT MANAGER's inspection.	LS	1		
1.17	Total Carried to Summary for Preliminaries				

ITEM	DESCRIPTION	UNIT	QTY	RATE	AMOUNT
1	<i>Preliminaries</i>				
	Materials Arising From Excavations				
1.18	Materials of any kind obtained from the excavations shall be the property of the Employer. Unless the PROJECT MANAGER directs otherwise such materials shall be dealt with as provided in the Contract. Such materials shall only be used in the works, in substitution of materials which the Contractor would otherwise have had to supply with the written permission of the PROJECT MANAGER. Should such permission be given, the Contractor shall make due allowance for the value of the materials so used at a price to be agreed.	LS	-		
	Materials on Site				
1.19	All materials for incorporation in the works must be stored on or adjacent to the site before payment is effected unless specifically exempted by the PROJECT MANAGER. This includes the material of the Main Contractor, Nominated Sub- Contractors and Nominated Suppliers.	LS	-		
	Government Acts Regarding Work, people etc.				
1.20	Allow for complying with all Government Acts, Orders and Regulations in connection with the employment of Labour and other matters related to the execution of the works. In particular the Contractor's attention is drawn to the provisions of the Factory Act 1950 and his tender must include for all costs arising or resulting from compliance with any Act, Order or Regulation relating to Insurances, pensions and holidays for workpeople or so the safety, health and welfare of the workpeople.	Lumps um	1		
1.21	Total Carried to Summary for Preliminaries				

ITEM	DESCRIPTION	UNIT	QTY	RATE	AMOUNT
1	<i>Preliminaries</i>				
	Accessibility and delivery of materials				
1.22	Allow for access and delivery of materials and equipment to remote locations that are not accessible by road. Note that some areas of the are inaccessible and materials may only delivered by manual labour. The area of work is majorly inaccessible and materials may only be delivered by manual labour. Contractor should put an extra cost for such transport or include it in his rates.	ITEM	1		
1.23	Allow for for training of the meintenncce team that will be resposible maitenanceof the fence througout the entire life of th fence including ; vegetation control, voltage monitoring, shorts tracing and removal, Tensioning of loose GHT wires and other maintenance works	Lumps um	1		
1.27	Total Carried to Summary for Preliminaries				
	Summary(Preliminaries)				
1.31	Brought Forward from ' 1.07 '				
1.32	Brought Forward from ' 1.13 '				
1.34	Brought Forward from ' 1.17 '				
1.36	Brought Forward from ' 1.21 '				
1.35	Brought Forward from ' 1.27 '				
1.37	TOTAL FOR PRELIMINARIES CARRIED FORWARD TO GRAND SUMMARY				

## BILL NO. 2: SITE CLEARANCE AND EARTHWORKS

ITEM	DESCRIPTION	UNIT	QTY	RATE	AMOUNT
2	<b>SITE CLEARANCE AND EARTHWORKS</b>				
	Total Length of fence is 30.63 Km				
2.00	<i>Site Clearance and Earthworks</i>				
2.01	The following shall form costs for construction/installation (Supply of materials and Installation only) of 9.10Km 10 strand intermediate Kenya Forest service (KFS) Electric fence as per the drawings and specifications: <u>Clearing of vegetation; earthworks, cutting of drains, Pegging; Excavation of holes to receive posts; Construction of assemblies: single; double and corner assemblies; Ramming of posts; Tying of Strainers and reels; Fixing of W - Insulators; Straining of wires, Fixing of gate; Construction of energizer houses; Powering; Testing and Commissioning; Handing over</u>				
2.02	SITE CLEARANCE				
2.03	Bush clearing 2m on either side of fence alignment and remove trees, hedges as directed by the engineer	Sm.	40,400		
2.04	Cut and remove trees (Approximate girth = ≤600mm) as directed by the Engineer	No.	500		
2.05	Cut and remove trees (Approximate girth 600 ≥ 1200 mm) as directed by the Engineer	No.			
2.06	Cut and remove trees (Approximate girth 1200 > mm) as directed by the Engineer	No.			
	EARTH WORKS				
2.09	Fill in approved soft material in selected areas as directed by Project Manager	CM	500		
2.10	As item A2 for compaction of top 300mm in fills in areas as directed by the engineer on site	CM	500		
2.11	TOTAL FOR SITE CLEARANCE AND EARTHWORKS CARRIED FORWARD TO GRAND SUMMARY				

**BILL NO. 3: FENCEWORKS**

ITEM	DESCRIPTION	UNIT	QTY	RATE	AMOUNT
3	<b>FENCE WORKS</b>				
	Note: The successful bidder will be required to submit one number samples of each of the following materials /items except for No. B1, B2 & A31 before signing of contract.				
3.01	Line Posts	Pc	6,279		
3.02	Strainer Posts	Pc	628		
3.03	2.5mm High Tensile Wire (HTS)	Roll (600M )	536		
3.04	4.0mm Soft wire	Roll (500M )	15		
3.05	Barbed wire guage 12.5	Rolls (180)	13		
3.06	2" Staple U - Nails	Kg	293		
3.07	5" Straight Nails (Assorted)	Kg.	100		
3.08	Earth Pegs	Pc	322		
3.09	Warning signs	Pc	310		
3.10	W-Insulators.	No.	62,792		
3.11	Strain End insulator	No.	3,063		
3.12	Joint Clamps	Pc	322		
3.13	Reel Insulator	No.	500		
3.14	Energizer 16 Joules stored Energy (Solar)	Pc	5		
3.15	300W Solar Panel	Pc	5		
3.16	200 Ah Solar battery	Pc	5		
3.17	Charge regulator 30AMPS	Pc	5		
3.18	5mm dia. Under gate cable	Roll (50m)	9		
3.19	2.5mm dia.twin cable	Roll (90m)	2		
3.20	25mm conduits	Pcs	30		
3.21	Flood gate controller	Pc	7		
3.22	Lightening Diverters/Arrestors	Pc	5		
3.23	Single strainers	Pc	5		
3.24	Maun cutting Pliers	Pc	5		
3.25	Wire dispenser	Pc	5		
3.26	Digital Voltmeters	Pc	5		
3.27	Hand held, petrol powered brush cutter complete with PPEs ( overal, leather glooves, helmet, gumboots, goggles, plastic musk and earmuffs.	Pc	5		
3.28	TOTAL FOR FENCEWORKS CARRIED FORWARD TO GRAND SUMMARY				



## BILL NO. 4: GATES

ITEM	DESCRIPTION	UNIT	QTY	RATE	AMOUNT
4	GATES				
4.1	MAIN GATE				
	GATE COLUMNS				
4.1.1	Over site excavation 200mm deep	SM	16.00		
4.1.2	Excavate for Gate Stanchion in soft material average size 300mm diameter 500 mm deep	CM	0.07		
4.1.3	Backfill with selected gravel material and compact	CM	6.40		
4.1.4	Cart away surplus excavated material	CM	2.00		
	Provide and place class 20/20 concrete in accordance with design				
4.1.5	To stanchion base	CM	0.07		
4.1.6	GATE STRUCTURE				
	Provide all materials and fabricate gate structure using mild steel grade 43 sections welded in grillage and erected to cast column				
4.1.7	75x75x3mm SHS stanchions	LM	6		
4.1.8	40x40x3mm SHS tubes for Gate frame structure	LM	15		
4.1.9	40x40x3mm SHS Horizontal intermediate members	LM	3		
4.1.10	25x25x2mm SHS vertical internal members	LM	42		
4.1.11	2 inch Steel Hinges	No.	6		
4.1.12	Provide steel locks as per drawing	No.	1		
4.1.13	Provide Tower Bolts as per drawing	No.	2		
	PAINTING				
4.1.14	Prepare and apply one coat of red oxide and two courts of primer to general metal surfaces	SM	13		
4.1.15	Prepare and apply one under coat and two prime coats of first quality gloss paint to sides of columns as directed by engineer	SM	5.7		
4.1.16	TOTAL FOR 1NO. MAIN GATE				
4.1.17	TOTAL FOR 6NO. MAIN GATES CARRIED FORWARD TO SUMMARY ('4.1.16' X 6)				

ITEM	DESCRIPTION	UNIT	QTY	RATE	AMOUNT
4	GATES				
4.2	PEDESTRIAN GATE				
	Earthworks				
4.2.1	Excavate oversite not exceeding 1500mm deep for foundation and cart away	m3	0.2		
	Concrete Works				
4.2.2	Provide and place vibrated concrete class 20/20 to foundation	m3	0.2		
	Stanchion				
4.2.3	75x75x3mm SHS stanchions anchored into concrete base	LM	6.0		
	Gate Structure				
4.2.4	40x40x3mm SHS main frame members	LM	8.8		
4.2.6	30x30x2mm SHS bracings	LM	16		
	Painting				
4.2.7	One undercoat and two finishing coats of gloss paint to surfaces of mild steel sections	SM	6.0		
4.2.8	Provide Steel Locks	LM	1.0		
4.2.9	Provide 1 inch Steel Hinges	No	2.0		
4.2.10	TOTAL FOR 1NO. PEDESTRIAN GATE				
4.2.11	TOTAL FOR 6NO. PEDESTRIAN GATES CARRIED FORWARD TO SUMMARY ('4.2.10' X 6)				
4.3	SUMMARY				
4.3.1	MAIN GATES	FROM	4.1.17		
4.3.2	PEDESTRIAN GATES	" "	4.2.11		
4.3.3	TOTAL FOR GATES CARRIED FORWARD TO GRAND SUMMARY				

**BILL NO. 5: BUFFER CHAIN LINK FENCE FOR PLAYING FIELD**

ITEM	DESCRIPTION	UNIT	QTY	RATE	AMOUNT
<u>5</u>	<u>BUFFER CHAINLINK FENCE FOR PLAYING FIELD</u>				
	<i>Approximate Length of Fence</i>	M	1350		
5.01	Excavate holes size 350mm Diameter x 500mm deep to receive posts	CM	26		
5.02	1:2:4 mass concrete cast insitu in post holes with concrete posts	CM	26		
5.03	150mm to 175mm diameter x3000mm treated timber posts at 3.0m c/c anchored in mass concrete (1:3:6) M/S	NO	451		
5.04	150mm to 175mm diameter x3000mm treated timber posts at 3.0m c/c anchored in mass concrete (1:3:6) M/S at every 30meters and at corners	NO	98		
5.05	8 feet high by 12.5 gauge with 50x50mm openings chainlink tied to 5No.line wire through the post	LM	1350		
5.06	12.5 gauge x 5 strand galvanized wire through concrete posts	LM	6750		
5.07	TOTAL FOR BUFFER CHAINLINK FENCE CARRIED FORWARD TO GRAND SUMMARY				

## BILL NO. 6: GRAND SUMMARY

ITEM	DESCRIPTION	UNIT	QTY	RATE	AMOUNT
6	<b>GRAND SUMMARY</b>				
6.01	PRELIMINARIES	From	1.37		
6.02	SITE CLEARANCE AND EARTHWORKS	From	2.11		
6.03	FENCE WORKS	From	3.28		
6.04	GATES	From	4.1.17		
6.05	BUFFER CHAIN LINK FENCE FOR PLAYING FIELD	From	5.07		
6.06	<b>SUB TOTAL 1</b>				
6.07	ADD 5% OF TOTAL COST AS CONTINGENCY				
6.08	<b>SUB TOTAL 2</b>				
6.09	ADD 16% VAT				
6.1	<b>GRAND TOTAL CARRIED TO FORM OF TENDER</b>				

1. AMOUNT IN WORDS .....
- .....
2. NAME OF BIDDER: .....
3. BIDDERS ADDRESS .....
4. STAMP: .....
5. NAME OF BIDDER'S REPRESENTATIVE: .....
6. SIGNATURE: ..... DATE: .....
7. NAME OF WITNESS: .....
8. ADDRESS OF WITNESS: .....
9. SIGNATURE: ..... DATE: .....

**Schedule of Adjustment Data**

**Table A - Local Currency**

Index Code	Index Description	Source of Index	Base Value and Date	Bidder's Local Currency Amount	Bidder's Proposed Weighting
	Nonadjustable	—	—	—	A: _____ B: _____ C: _____ D: _____ E: _____
<b>Total</b>					<b>1.00</b>

**Table B - Foreign Currency**

Name of Currency: \_\_\_\_\_

If the Bidder wishes to quote in more than one foreign currency, this table should be repeated for each foreign currency.

Index Code	Index Description	Source of Index	Base Value and Date	Bidder's Currency in Type/Amount	Equivalent in FC1	Bidder's Proposed Weighting
	Nonadjustable	—	—	—		A: _____ B: _____ C: _____ D: _____ E: _____
<b>Total</b>						<b>1.00</b>



## Summary of Payment Currencies

**Table: Alternative A**

**For**.....insert name of Section of the Works

Separate tables may be required if the various sections of the Works (or of the Bill of Quantities) will have substantially different foreign and local currency requirements. The Employer should insert the names of each Section of the Works.

	A	B	C	D
Name of Payment Currency	Amount of Currency	Rate of Exchange to Local Currency	Local Currency Equivalent $C = A \times B$	Percentage of Net Bid Price (NBP) $\frac{100 \times C}{NBP}$
Local currency _____		1.00		
Foreign Currency #1 _____				
Foreign Currency #2 _____				
Foreign Currency #3 _____				
Net Bid Price				100.00
Provisional Sums Expressed in Local Currency		1.00		
<b>BID PRICE</b>				

**Table: Alternative B**

**To be used only with Alternative B Prices directly quoted in the currencies of payment.**

(Clause **ITB** 15.1)

Summary of currencies of the bid for \_\_\_\_\_ [insert name of Section of the Works]

Name of currency	Amounts payable
Local currency: _____	
Foreign currency #1: _____	
Foreign currency #2: _____	
Foreign currency #3: _____	

## Form of Bid Security (Bank Guarantee)

\_\_\_\_\_ [Bank's Name, and Address of Issuing Branch or Office]

**Beneficiary:** \_\_\_\_\_ [Name and Address of Employer]

**Date:** \_\_\_\_\_

**BID GUARANTEE No.:** \_\_\_\_\_

We have been informed that \_\_\_\_\_ [name of the Bidder] (hereinafter called "the Bidder") has submitted to you its bid dated \_\_\_\_\_ (hereinafter called "the Bid") for the execution of \_\_\_\_\_ [name of contract] under Invitation for Bids No. \_\_\_\_\_ ("the IFB").

Furthermore, we understand that, according to your conditions, bids must be supported by a bid guarantee.

At the request of the Employer, we \_\_\_\_\_ [name of Bank] hereby irrevocably undertake to pay you any sum or sums not exceeding in total an amount of \_\_\_\_\_ [amount in figures] (\_\_\_\_\_) [amount in words] upon receipt by us of your first demand in writing accompanied by a written statement stating that the Bidder is in breach of its obligation(s) under the bid conditions, because the Bidder:

- (a) has withdrawn its Bid during the period of bid validity specified by the Bidder in the Form of Bid; or
- (b) having been notified of the acceptance of its Bid by the Employer during the period of bid validity, (i) fails or refuses to execute the Contract Form, if required, or (ii) fails or refuses to furnish the performance security, in accordance with **ITB 38**.

This guarantee will expire: (a) if the Bidder is the successful Bidder, upon our receipt of copies of the contract signed by the Bidder and the performance security issued to you upon the instruction of the Bidder; and (b) if the Bidder is not the successful Bidder, upon the earlier of (i) our receipt of a copy your notification to the Bidder of the name of the successful Bidder; or (ii) twenty-eight days after the expiration of the Bidder's bid.

Consequently, any demand for payment under this guarantee must be received by us at the office on or before that date.

This guarantee is subject to the Uniform Rules for Demand Guarantees, ICC Publication No. 458.

---

[signature(s)]

## Form of Bid Security (Bid Bond)

BOND NO. \_\_\_\_\_

BY THIS BOND [name of Bidder] as Principal (hereinafter called “the Principal”), and [name, legal title, and address of surety], **authorized to transact business in** [name of country of Employer], as Surety (hereinafter called “the Surety”), are held and firmly bound unto [name of Employer] as Obligee (hereinafter called “the Employer”) in the sum of [amount of Bond]<sup>10</sup> [amount in words], for the payment of which sum, well and truly to be made, we, the said Principal and Surety, bind ourselves, our successors and assigns, jointly and severally, firmly by these presents.

WHEREAS the Principal has submitted a written Bid to the Employer dated the \_\_\_\_ day of \_\_\_\_\_, 20\_\_, for the construction of [name of Contract] (hereinafter called the “Bid”).

NOW, THEREFORE, THE CONDITION OF THIS OBLIGATION is such that if the Principal:

- (a) withdraws its Bid during the period of bid validity specified in the Form of Bid; or
- (b) having been notified of the acceptance of its Bid by the Employer during the period of Bid validity; (i) fails or refuses to execute the Contract Form, if required; or (ii) fails or refuses to furnish the Performance Security in accordance with the Instructions to Bidders;

then the Surety undertakes to immediately pay to the Employer up to the above amount upon receipt of the Employer’s first written demand, without the Employer having to substantiate its demand, provided that in its demand the Employer shall state that the demand arises from the occurrence of any of the above events, specifying which event(s) has occurred.

The Surety hereby agrees that its obligation will remain in full force and effect up to and including the date 28 days after the date of expiration of the Bid validity as stated in the Invitation to Bid or extended by the Employer at any time prior to this date, notice of which extension(s) to the Surety being hereby waived.

IN TESTIMONY WHEREOF, the Principal and the Surety have caused these presents to be executed in their respective names this \_\_\_\_ day of \_\_\_\_\_ 20\_\_.

Principal: \_\_\_\_\_

Surety: \_\_\_\_\_  
Corporate Seal (where appropriate)

<sup>10</sup> The amount of the Bond shall be denominated in the currency of the Employer’s country or the equivalent amount in a freely convertible currency.

\_\_\_\_\_  
(Signature)

(Printed name and title)

\_\_\_\_\_  
(Signature)

(Printed name and title)

## Form of Bid-Securing Declaration

Date: [insert date (as day, month and year)]

Bid No.: [insert number of bidding process]

Alternative No.: [insert identification No if this is a Bid for an alternative]

To: [insert complete name of Employer]

We, the undersigned, declare that:

We understand that, according to your conditions, bids must be supported by a Bid-Securing Declaration.

We accept that we will automatically be suspended from being eligible for bidding in any contract with the Borrower for the period of time of [**Employer to insert number of months or years**] starting on [**insert date**], if we are in breach of our obligation(s) under the bid conditions, because we:

- (a) have withdrawn our Bid during the period of bid validity specified in the Letter of Bid; or
- (b) having been notified of the acceptance of our Bid by the Employer during the period of bid validity, (i) fail or refuse to execute the Contract, if required, or (ii) fail or refuse to furnish the Performance Security, in accordance with **ITB 38**.

We understand this Bid-Securing Declaration shall expire if we are not the successful Bidder, upon the earlier of (i) our receipt of your notification to us of the name of the successful Bidder; or (ii) twenty-eight days after the expiration of our Bid.

Signed: [insert signature of person whose name and capacity are shown] In the capacity of [insert legal capacity of person signing the Bid-Securing Declaration]

Name: [insert complete name of person signing the Bid-Securing Declaration]

Duly authorized to sign the bid for and on behalf of: [insert complete name of Bidder]

Dated on \_\_\_\_\_ day of \_\_\_\_\_, \_\_\_\_\_ [insert date of signing]

Corporate Seal (where appropriate)

[Note: In case of a Joint Venture, the Bid-Securing Declaration must be in the name of all partners to the Joint Venture that submits the bid.]



## **Technical Proposal**

### Technical Proposal Forms

**Site Organization**

**Method Statement**

**Mobilization Schedule**

**Construction Schedule**

**Contractor's Equipment**

**Personnel**

**Others**

<p><b>Site Organization</b></p>
---------------------------------

<p><b>Method Statement</b></p>
--------------------------------

<p><b>Mobilization Schedule</b></p>
-------------------------------------

**Construction Schedule**

## Contractor's Equipment

### Form EQU

The Bidder shall provide adequate information to demonstrate clearly that it has the capability to meet the requirements for the key equipment listed in Section III, Evaluation and Qualification Criteria. A separate Form shall be prepared for each item of equipment listed, or for alternative equipment proposed by the Bidder. The Bidder shall provide all the information requested below, to the extent possible. Fields with asterisk (\*) shall be used for evaluation.

<b>Type of Equipment*</b>	
<b>Equipment Information</b>	<b>Name of manufacturer</b>
	<b>Model and power rating</b>
	<b>Capacity*</b>
	<b>Year of manufacture*</b>
<b>Current Status</b>	<b>Current location</b>
	<b>Details of current commitments</b>
<b>Source</b>	<b>Indicate source of the equipment</b> <input type="checkbox"/> Owned <input type="checkbox"/> Rented <input type="checkbox"/> Leased <input type="checkbox"/> Specially manufactured

The following information shall be provided only for equipment not owned by the Bidder.

<b>Owner</b>	<b>Name of owner</b>	
	<b>Address of owner</b>	
	<b>Telephone</b>	<b>Contact name and title</b>
	<b>Fax</b>	<b>Telex</b>
<b>Agreements</b>	<b>Details of rental / lease / manufacture agreements specific to the project</b>	

**Proposed Personnel**

Form PER – 1

Bidders should provide the names of suitably qualified personnel to meet the specified requirements for each of the positions listed in Section III, Evaluation and Qualification Criteria. The data on their experience should be supplied using the Form below for each candidate.

<b>1.</b>	<b>Title of position</b>
	<b>Name</b>
<b>2.</b>	<b>Title of position</b>
	<b>Name</b>
<b>3.</b>	<b>Title of position</b>
	<b>Name</b>
<b>4.</b>	<b>Title of position</b>
	<b>Name</b>
<b>5.</b>	<b>Title of position</b>
	<b>Name</b>
<b>6.</b>	<b>Title of position</b>
	<b>Name</b>
<b>etc.</b>	<b>Title of position</b>
	<b>Name</b>





**Others**

<h2 style="text-align: center;"><b>Bidder's Qualification</b></h2>
--

To establish its qualifications to perform the contract in accordance with Section III, Evaluation and Qualification Criteria, the Bidder shall provide the information requested in the corresponding Information Sheets included hereunder.

## Bidder Information Sheet

Form ELI - 1.1

Date: \_\_\_\_\_

Bidding No.: \_\_\_\_\_

Invitation for Bid No.: \_\_\_\_\_

Page \_\_\_\_\_ of \_\_\_\_\_ pages

1. Bidder's Legal Name
2. In case of Joint Venture, Consortium or Association (JVCA), legal name of each party:
3. Bidder's actual or intended Country of Registration:
4. Bidder's Year of Registration:
5. Bidder's Legal Address in Country of Registration:
<p>6. Bidder's Authorized Representative Information</p> <p>Name:</p> <p>Address:</p> <p>Telephone/Fax numbers:</p> <p>Email Address:</p>
<p>7. Attached are copies of original documents of:</p> <p><input type="checkbox"/> Articles of Incorporation or Registration of firm named in 1, above, in accordance with <b>ITB</b> Clauses 4.1 and 4.2.</p> <p><input type="checkbox"/> In case of JVCA, letter of intent to form JVCA including a draft agreement, or JVCA agreement, in accordance with <b>ITB</b> Clause 4.1</p> <p><input type="checkbox"/> In case of government owned entity from the Employer's country, documents establishing legal and financial autonomy and compliance with the principles of commercial law, in accordance with <b>ITB</b> Clause 4.5.</p>

## Party to JVCA Information Sheet

Form ELI - 1.2

Date: \_\_\_\_\_  
 Bidding No.: \_\_\_\_\_  
 Invitation for Bid No.: \_\_\_\_\_  
 Page \_\_\_\_\_ of \_\_\_\_\_ pages

1. Bidder's Legal Name:
2. JVCA's Party legal name:
3. JVCA's Party Country of Registration:
4. JVCA's Party Year of Registration:
5. JVCA's Party Legal Address in Country of Registration:
6. JVCA's Party Authorized Representative Information Name: Address: Telephone/Fax numbers: Email Address:
7. Attached are copies of original documents of: <ul style="list-style-type: none"> <li><input type="checkbox"/> Articles of Incorporation or Registration of firm named in 1, above, in accordance with <b>ITB</b> Clauses 4.1 and 4.2.</li> <li><input type="checkbox"/> In case of government owned entity from the Purchaser's country, documents establishing legal and financial autonomy and compliance with the principles of commercial law, in accordance with <b>ITB</b> Clause 4.5.</li> </ul>

## Historical Contract Non-Performance

Form CON – 2

Bidder's Legal Name: \_\_\_\_\_

Date: \_\_\_\_\_

JVCA Partner Legal Name: \_\_\_\_\_

Bidding No.: \_\_\_\_\_

Page \_\_\_\_\_ of \_\_\_\_\_ pages

Non-Performing Contracts in accordance with (Evaluation and Qualification Criteria)			
<input type="checkbox"/> Contract non-performance did not occur during the stipulated period, in accordance with Sub-Factor 2.2.1 of Section III, Evaluation and Qualification Criteria.			
<input type="checkbox"/> Contract non-performance during the stipulated period, in accordance with Sub-Factor 2.2.1 of Section III, Evaluation and Qualification Criteria.			
Year	Outcome as Percent of Total Assets	Contract Identification	Total Contract Amount (current value, US\$ equivalent)
_____	_____	Contract Identification: Name of Employer: Address of Employer: Matter in dispute:	_____
Pending Litigation, in accordance with Section III, Evaluation and Qualification Criteria			
<input type="checkbox"/> No pending litigation in accordance with Sub-Factor 2.2.3 of Section III, Evaluation and Qualification Criteria.			
<input type="checkbox"/> Pending litigation in accordance with Sub-Factor 2.2.3 of Section III, Evaluation and Qualification Criteria, as indicated below			
Year	Outcome as Percent of Total Assets	Contract Identification	Total Contract Amount (current value, US\$ equivalent)
_____	_____	Contract Identification: Name of Employer: Address of Employer: Matter in dispute:	_____
_____	_____	Contract Identification: Name of Employer: Address of Employer: Matter in dispute:	_____

## Current Contract Commitments / Works in Progress

### Form CCC

Bidders and each partner to a JVCA should provide information on their current commitments on all contracts that have been awarded, or for which a letter of intent or acceptance has been received, or for contracts approaching completion, but for which an unqualified, full completion certificate has yet to be issued.

Name of contract	Employer, contact address/tel/fax	Value of outstanding work (current US\$ equivalent)	Estimated completion date	Average monthly invoicing over last six months (US\$/month)
1.				
2.				
3.				
4.				
5.				
etc.				

## Financial Situation

Form FIN – 3.1

### Historical Financial Performance

Bidder’s Legal Name: \_\_\_\_\_ Date: \_\_\_\_\_

JVCA Partner Legal Name: \_\_\_\_\_ Bidding No.: \_\_\_\_\_

Page \_\_\_\_\_ of \_\_\_\_\_ pages

To be completed by the Bidder and, if JVCA, by each partner

Financial information in US\$ equivalent	Historic information for previous _____ ( ) years (US\$ equivalent in 000s)						
	Year 1	Year 2	Year 3	Year ...	Year n	Avg.	Avg. Ratio
<b>Information from Balance Sheet</b>							
Total Assets (TA)							
Total Liabilities (TL)							
Net Worth (NW)							
Current Assets (CA)							
Current Liabilities (CL)							
<b>Information from Income Statement</b>							
Total Revenue (TR)							
Profits Before Taxes (PBT)							

- Attached are copies of financial statements (balance sheets, including all related notes, and income statements) for the years required above complying with the following conditions:
  - Must reflect the financial situation of the Bidder or partner to a JVCA, and not sister or parent companies
  - Historic financial statements must be audited by a certified accountant
  - Historic financial statements must be complete, including all notes to the financial statements
  - Historic financial statements must correspond to accounting periods already completed and audited (no statements for partial periods shall be requested or accepted)



## Average Annual Turnover

Form FIN – 3.2

Bidder’s Legal Name: \_\_\_\_\_ Date: \_\_\_\_\_  
 JVCA Partner Legal Name: \_\_\_\_\_ Bidding No.: \_\_\_\_\_  
 Page \_\_\_\_\_ of \_\_\_\_\_ pages

Annual turnover data (construction only)		
Year	Amount and Currency	US\$ equivalent
	_____	_____
	_____	_____
	_____	_____
	_____	_____
	_____	_____
	_____	_____
*Average Annual Construction Turnover	_____	_____

\*Average annual turnover calculated as total certified payments received for work in progress or completed over the number of years specified in Section III, Evaluation and Qualification Criteria, Sub-Factor 2.3.2, divided by that same number of years.

**Financial Resources**

## Form FIN – 3.3

Specify proposed sources of financing, such as liquid assets, unencumbered real assets, lines of credit, and other financial means, net of current commitments, available to meet the total construction cash flow demands of the subject contract or contracts as indicated in Section III, Evaluation and Qualification Criteria.

Source of financing	Amount (KES)
1.	
2.	
3.	
4.	

## General Experience

Form EXP – 2.4.1

Bidder's Legal Name: \_\_\_\_\_ Date: \_\_\_\_\_  
 JVCA Partner Legal Name: \_\_\_\_\_ Bidding No.: \_\_\_\_\_  
 Page \_\_\_\_\_ of \_\_\_\_\_ pages

Starting Month / Year	Ending Month / Year	Years*	Contract Identification	Role of Bidder
_____	_____		Contract name: Brief Description of the Works performed by the Bidder: Name of Employer: Address:	_____
_____	_____		Contract name: Brief Description of the Works performed by the Bidder: Name of Employer: Address:	_____
_____	_____		Contract name: Brief Description of the Works performed by the Bidder: Name of Employer: Address:	_____
_____	_____		Contract name: Brief Description of the Works performed by the Bidder: Name of Employer: Address:	_____
_____	_____		Contract name: Brief Description of the Works performed by the Bidder: Name of Employer: Address:	_____
_____	_____		Contract name: Brief Description of the Works performed by the Bidder: Name of Employer: Address:	_____

\*List calendar year for years with contracts with at least nine (9) months activity per year starting with the earliest year

## Specific Experience

Form EXP – 2.4.2(a)

Bidder's Legal Name: \_\_\_\_\_ Date: \_\_\_\_\_

JVCA Partner Legal Name: \_\_\_\_\_ Bidding No.: \_\_\_\_\_

Page \_\_\_\_\_ of \_\_\_\_\_ pages

<b>Similar Contract Number: __[insert specific number] of __[insert total number of contracts required].</b>	<b>Information</b>		
Contract Identification			
Award date			
Completion date			
Role in Contract	<input type="checkbox"/> Contractor	<input type="checkbox"/> Management Contractor	<input type="checkbox"/> Subcontractor
Total contract amount			US\$ _____ _____
If partner in a JVCA or subcontractor, specify participation of total contract amount	_____ %		US\$ _____ _____
Employer's Name:			
Address:			
Telephone/fax number:			
E-mail:			

**Specific Experience (cont.)**

Form EXP – 2.4.2(a) (cont.)

Bidder’s Legal Name: \_\_\_\_\_ Page \_\_\_\_\_ of \_\_\_\_\_ pages  
 JVCA Partner Legal Name: \_\_\_\_\_

<b>Similar Contract No. __[insert specific number] of __[insert total number of contracts] required</b>	<b>Information</b>
Description of the similarity in accordance with Sub-Factor 2.4.2(a) of Section III, Evaluation and Qualification Criteria:	
Amount	_____
Physical size	_____
Complexity	_____
Methods/Technology	_____
Physical Production Rate	_____

## Specific Experience in Key Activities

Form EXP – 2.4.2(b)

Bidder's Legal Name: \_\_\_\_\_ Date: \_\_\_\_\_  
 JVCA Partner Legal Name: \_\_\_\_\_ Bidding No.: \_\_\_\_\_  
 Subcontractor's Legal Name: \_\_\_\_\_ Page \_\_\_\_\_ of \_\_\_\_\_ pages

	Information		
Contract Identification	_____		
Award date	_____		
Completion date	_____		
Role in Contract	<input type="checkbox"/> Contractor	<input type="checkbox"/> Management Contractor	<input type="checkbox"/> Subcontractor
Total contract amount	_____		US\$ _____
If partner in a JVCA or subcontractor, specify participation of total contract amount	_____ %	_____	US\$ _____
Employer's Name:	_____		
Address:	_____ _____ _____		
Telephone/fax number:	_____		
E-mail:	_____		

**Specific Experience in Key Activities (cont.)**

Form EXP – 2.4.2(b) (cont.)

Bidder’s Legal Name: \_\_\_\_\_ Page \_\_\_\_\_ of \_\_\_\_\_ pages  
 JVCA Partner Legal Name: \_\_\_\_\_  
 Subcontractor’s Legal Name: \_\_\_\_\_

	Information
Description of the key activities in accordance with Sub-Factor 2.4.2(b) of Section III, Evaluation and Qualification Criteria:	
Amount	
Physical size	
Complexity	
Methods/Technology	
Physical Production Rate	

## Section V. Eligible Countries

### **Eligibility for the Provision of Goods, Works and Related Services in Bank-financed Procurement**

#### **A. Provision at Paragraph 1.6 of the Bank's Rules and Procedures for Procurement of Goods and Works**

1.6 The African Development Fund permits firms and individuals from all countries to offer goods, works and services for ADF funded projects. However, the proceeds of any Financing undertaken in the operations of the African Development Bank and the Nigeria Trust Fund shall be used for procurement of goods and works, including the related services, provided by bidders from Eligible<sup>11</sup> Countries.<sup>12</sup> Any conditions for participation shall be limited to those that are essential to ensure the firm's capability to fulfill the contract in question. In the case of ADB and NTF, bidders from non-Member Countries offering goods, works and related services (including transportation and insurance) are not eligible even if they offer these from Eligible Member Countries. Any waiver to this rule will be in accordance with the Articles 17(1) (d) of the Agreement Establishing the African Development Bank and 4.1 of the Agreement Establishing the Nigeria Trust Fund.

#### **B. Provision at Appendix 4 of the Bank's Rules and Procedures for Procurement of Goods and Works**

### **Overview**

1. The eligibility criteria for participation in the supply of goods, works and related services, to be procured through the ADB and NTF Financing, derive from the requirements of the Agreement Establishing the African Development Bank, Article 17.1.d, and the Agreement Establishing the Nigeria Trust Fund, Article 4.1. The foregoing requirements basically prescribe two types of eligibility criteria:

- (a) The eligibility of the bidder;
- (b) The eligibility of the goods, works and related services.

---

<sup>11</sup> Refer to Appendix 4 for additional information on Eligibility.

<sup>12</sup> "Eligible Countries" shall mean: (a) in the case of the African Development Bank and the Nigeria trust Fund, the Member Countries of the African Development Bank.



**Eligibility of the Bidder**

2. The eligibility of the bidder shall be based on nationality, in accordance with the following rules:

- (a) Natural Persons: A natural person is eligible if he or she is a national of a Member Country of the Bank, or a State Participant of the Fund. Where a person has more than one nationality, such a person shall be eligible if the nationality indicated in his or her bid is that of a Member Country of the Bank, or a State Participant of the Fund.
- (b) Corporations: A corporation is eligible if it satisfies the following criteria:
  1. it is incorporated in a country that is a Member of the Bank, or State Participant of the Fund;
  2. it is a national of a country that is a Member of the Bank, or State Participant of the Fund, as determined by the law of its place of incorporation;
  3. it has its principal place of business in a country that is a Member of the Bank, or State Participant of the Fund.
- (c) Joint Ventures and Associations: An unincorporated joint venture, partnership, or association, shall be eligible if at least 60% of its individual, or corporate members, satisfy the eligibility requirement for individuals or corporations.

**Eligibility of the Goods, Works and Related Services**

3. In order to be eligible, the goods to be procured must have been mined, grown, or produced, in the form in which they are purchased, in an Eligible Member Country.

4. For works contracts, which may include civil works, plant construction, or turnkey contracts, the contractor must satisfy the nationality criteria of eligibility, either as a natural person, or corporation, or joint venture and association. Labour, equipment, and materials needed for carrying out the works contract, shall be supplied from Eligible Member Countries.

5. For contracts, which have been awarded on the basis of Cost, Insurance and Freight (CIF), or Carriage and Insurance Paid (CIP), bidders shall be free to arrange for ocean and other transportation, and the related insurance, from any Eligible Member Country. On the other hand, where goods are shipped on FOB basis, and the Bank has agreed to finance transportation and insurance separately, which are arranged by the purchaser, under a separate contract, the Bank shall be satisfied that the services are supplied from Eligible Member Countries.

**C. Eligible Countries**

## **PART 2 – Employer’s Requirement**

**Section VI. Requirements**

**Table of Contents**

**Specifications .....86**

**Drawings .....873**

**Supplementary Information.....885**

**SPECIFICATIONS FOR CONSTRUCTION  
OF ELECTRIC PERIMETER FENCE FOR  
KAPCHUMBE FOREST BLOCK IN BOMET  
COUNTY**



## **GREEN ZONES DEVELOPMENT SUPPORT PROGRAMME II**

### **DESIGN AND SPECIFICATIONS FOR CHEPALUNGU FOREST, KAPCHUMBE BLOCK ELECTRIC FENCE**

#### **1.0 GENERAL SPECIFICATIONS**

The following specifications shall apply in this project:

- a) Ministry of Public Works Standard Specification for roads and Bridge construction
- b) MOPW specification for Building construction
- c) Specification for steel wires and wire products used for fencing (KS 06-261-1987)
- d) Specification for preservation of Timber (KS 02-94-19) (special specification)

#### **1.1 CLEARING OF THE FENCE ALIGNMENT**

Within a corridor of Nine (9m) width along the community/Forest boundary will be the fence alignment to be cleared of all vegetation and top soil up to a depth of 200mm cut away and disposed within the eased area.

The ground within the corridor shall be levelled by grading, set so as to leave a 2m width of the corridor to either side of fence to serve as fire break and service road and sloped as is most suitable according to terrain so as to allow for surface drainage.

#### **1.2 DRAINAGE AND EARTHWORKS**

Where necessary, catch water, cutoff and side/miter drains shall be cut

## Specifications for Electric Fence

---

with an earth moving equipment or human labor to deviate run off from the service road. Simple drainage structures ( culverts or drifts) shall be constructed where identified by the supervisor.

Where necessary forming the appropriate cross sections shall involve cutting and filling and in such cases the fill shall be compacted in layers to 95% MDD ASHTO T99 in accordance with the Standard Specification for road and Bridge Construction.

### 2.0 FENCE DESIGN

A line of 30.63 Km ten strand electric fence on one side shall be constructed on a cleared corridor in a manner explained below and using the materials given.

#### Fence Design Specification

The fence shall be of intermediate fence Design as explained below.

- (i) The electric fence shall consist of ten strands on one side of the fence posts. There shall be six live wires and four earth spaced equally from bottom to the top at 200mm interval. The wire shall be attached to a 2m earth peg with a joint clamp.
- (ii) All live wires shall be attached to strain insulators at strainer assemblies and tied by joint clamps and looped across king post to the next wire tied in the same way.
- (iii) Galvanized staples shall be used to attach earth wires and insulators to the posts. All wires shall be strained to a tension of 180kg. Standard galvanized joint clamps shall be used to join the wire along the main fence line and at corners where looping shall be necessary. All joints shall be tight and of figure 8 or reef knot joint

### 2.1

#### POSTS

##### 2.1.1 Line Posts

All line posts shall have a minimum diameter of 150mm and height of 3050mm and shall be spaced at 5,000mm on level ground (slope <5%). The spacing will be reduced to 3000mm on sloppy and undulating terrain (slope of >5%). They shall have a smooth and cylindrical surface free of knots and cracks.

## Specifications for Electric Fence

---

The posts shall be set in holes 450mm wide by 950 mm in depth in such a manner that 2100mm will be above the ground. The posts shall be embedded all round in 1.3.6 concrete with a cover of 150mm in swampy or rocky areas.

### 2.1.2 Strainer Posts

Strainer shall be built where there is change in the fence alignment both horizontal and vertical change (corner or depression) and at every 200m on a straight line.

The strainer assembly consists of the King posts, 2No. Strainer posts and two struts as shown in fig. 2. They shall all be 150 – 175mm diameter 3150mm in height. The strainer posts shall be connected to the King posts by a 2000mm long 150mm diameter strut (side arms) Fastening shall be by means of ordinary galvanized wire nails 125mm long.

4.0mm heavily galvanized soft wire shall be tied in 4 rounds diagonally from the supporter posts to the bottom of the King posts and twined to form a stay wire and held in place by use of 50mm heavily galvanized staple nails nailed to hold in place. The posts shall all be embedded all round in 1.3.6 concrete in a pre-dug hole measuring 525mm diameter and 1050mm in depth. They shall be set in such a way that 2100mm is above ground level. A minimum of 4days will be allowed for the curing of the concrete during which period no external forces shall be exerted on the posts.

## 2.2 WIRE

### 2.2.1 Plain Wire

#### i) Livewire

Plain wire to be used for live wire shall be High Tensile Steel wire 2.5mm diameter heavily galvanized to a zinc coating of not less than 280gm/m<sup>2</sup> and of steel class BS 1044 or BS 1065 and tensile strength of between 1200 and 1400N/mm<sup>2</sup>. The wire shall be strained on each end on porcelain strain insulator and run through W-plastic insulators nailed to posts by use of deep sunk heavily galvanized 2” U-nails.

#### ii) Earth Wire

The earth wires shall be as the live wires above in terms of specification and spacing

### 3.0 ELECTRIFICATION

#### i) Power

##### Source

Source of power shall be from solar panels & battery power shall be used. One Energizer of at least 58joules stored energy Solar/ Battery Energizer of at least 16 joules stored energy shall be used for every 8km of fence. The electrics shall be housed in an Energizer room built at intervals of 8km where one room can power two sections running to opposite directions. The houses will have provision for accommodation for fence attendants who will take care of the electrics and maintenance of the fence.

#### ii) Double Insulated Lead wires

Lead Wire (Under gate cable) in PVC pipe will carry power from the energizer house to the fence and the same to be used where there is any crossing like across gates, roads, grids, bridges over pass, under pass. At every passage there will be a cut out switch. The lead out cable shall be of 2.5mm diameter, double insulated in heavy duty polyethylene UV protected PVC material, put through a 25mm heavy gauge PVC pipe and laid 500mm below ground level. U-bends shall be constructed using bends, elbows and unions at points where the lead out wire goes into or comes out of the ground for the bend to face downwards.

#### iii) Lightning Diverter

At every energizer installation there will be a set of Lightning diverter installation for protection of the electrics. The diverter shall have a well-constructed loop and choke assembly complete with PVC supporter.

#### iv) Earthing for Energizer

This shall be identical to earthing for the fence but shall be provided separately using 7No. Earth pegs set at 2m spacing. At the same area there will be earthing for the lightning arrester which will consist of 6No. Pegs also at interval of 2m.

#### v) Crossing Gorges



## Specifications for Electric Fence

---

In Areas with gorges and dry river beds, there shall be a strainer assembly on either side at a height of 6m above the highest water level. The overhead fence across the valley shall be of the six electrified wires only.

A flood gate controller will be installed at every river, gorge or valley crossing.

### 4.0 GATES

Gates shall be constructed at strategic points to be determined on site.

### 5.0 DETAIL SPECIFICATIONS

#### 5.1 Posts

##### a) Wooden Posts – Strainers

- i) All wooden posts shall be of hardwood wattle or eucalyptus.
- ii) Pressure treated in cultured copper chrome arsenate (CCA)(tonality)C to the Chemical penetration of at least 1” (25mm)
- iii) Size shall be at least 6-7” (150mm – 175mm) diameter, length 11ft
- iv) Knot free and split free
- v) Bound at top and bottom by a HTS wire 2.5mm four times and stapled by 1” Staple nail.
- vi) Not more than one year’s Kenya Bureau of Standards Test Certificate required bearing bidders Name-.

##### b) Wooden Posts - Line posts

- i) All wooden posts shall be of hardwood wattle or eucalyptus.
- ii) Pressure treated in copper chrome arsenate (CCA)(tonality)C to the chemical penetration of at least 1” (25mm)
- iii) Size shall be at least 5-6” diameter, length 10ft.
- iv) Knot free and split free
- v) Bound at top and bottom by a HTS wire 2.5mm four times and stapled by 1” staple nail.
- vi) Not more than one year’s Kenya Bureau of Standards Test Certificate required bearing bidders Name

##### c) Wires

- i) Plain Wire 2.5mm HTS Plain  
wire to be used shall be: -

## Specifications for Electric Fence

---

1. High tensile steel wire of steel class BS 1044 or BS 1065
2. Size for live and earth wires shall be 2.5mm diameter with a tolerance of 0.02mm.
3. Shall have a tensile strength of 1200-1400 N/mm<sup>2</sup>
4. Shall have a weight of zinc coating of not less than 280gm/m<sup>2</sup>
5. Not more than one year Kenya Bureau of Standards Test Certificate required.

### ii) Soft Wire/stay wire

1. Shall be of mild steel wire.
2. Shall have weight of zinc coating of not less than 280gm/m<sup>2</sup>
3. Kenya Bureau of Standards Test Certificate required
4. Size shall be 4.0mm diameter mainly used for stay and cross wire on a Strainer Assembly.
5. Shall have tensile strength of not less than 500N/mm<sup>2</sup>

### d) Staples Nails (U-nails)

Staples (U-nails) shall be:

- i) Heavily galvanized wire nails
- ii) Long shank
- iii) 2 inches
- iv) Hot dipped.
- v) 4mm wire gauge.

### e) Insulators

#### i) Line Insulators

1. W-Insulators
2. Polyethylene material
3. Open-face for good drainage
4. With holes for anchoring staples
5. Made of UV protected polythene material
6. Strong jaws to withstand large horizontal and vertical movements.

#### ii) Strain end Insulators

1. Bull nose type
2. Porcelain material
3. Fire resistant
4. Long tracking distance
5. High quality white glaze finish

iii) **Corner and Line Insulator**

1. Reel round Insulator
2. Porcelain material
3. Fire resistant
4. High quality glaze finish
5. 41mm (1.5") diameter

f) **Energizers**

- (i) Solar Powered energizers
- (ii) Shall be fully modular
- (iii) 16 joules stored energy
- (iv) In built lightning protection

g) **Others**

i) **Lightning Diverter/ Arrester**

At all places where energizers are installed there shall be a lightning diverter

1. Standard lightning diverter is completed with spiral wire earthing system connection.
2. Adjustable to suit any module.
3. Shall be able to divert multiple lightning strikes to the ground (earth)
4. Size 90x100x60mm

ii) **Earth peg**

1. 2mx20mm diameter GI pipe class C
2. With a heavily galvanized Joint clamp 200mm below the upper tip
3. Heavily galvanized not less than 500gm/Sq m
4. Kenya Bureau of Standards Test Certificate required

iii) **Solar Panel - 300Watts Solar Panels**

h) **Solar Battery**

Shall be:

Clause	Specification	Compliance Values /Brand/ Country of Origin to be Printed in this Column

Specifications for Electric Fence

I	Brochures/Catalogue/Data Sheet of the equipment shall be submitted with the quotation response highlighting the particular product on offer in the brochures. Bids without technical brochures shall <u>NOT</u> be evaluated.	
II	Lead Acid Flooded Solar Battery	
III	Battery Capacity - 12V/ $\geq$ 200Ah Lead Acid Flooded / Gel with catalyst Battery at C20 Rating	
IV	Deep Cycle Solar Battery Technology.	
V	Dry Charged / Maintenance free	
VI	Plate Design - Tubular Plates	
VII	Battery Casing shall be Transparent (Clear Glass) with Minimum/Maximum electrolyte level markings for clear Electrolyte Level Inspection and Maintenance.	
VIII	Battery acid of the correct specific gravity recommended by the manufacturer shall be supplied separately in plastic containers for ease of transportation and safety.	
IX	Warranty Period – Minimum 2 Years	

i) Charge Controller/regulator

Clause	Specification	Compliance Values/Brand/ Country of Origin to be Printed in this Column
I	Brochures/Catalogue/Data Sheet of the equipment shall be submitted with the quotation response highlighting the particular product on offer in the brochures. Bids without technical brochures shall NOT be evaluated.	
II	; 12V/30A Solar Charge Controller with LCD display / Digital Meter that will display;	
III	System Voltage ; 12V/24 AutoDetect	

## Specifications for Electric Fence

---

IV	Maximum Output Current ; 30A Continuous Rating	
V	Electronic Protections ; Reverse Current at Night	
VI	Charging Regulation ; Bulk, Absorption, Float, Equalize	
VII	Technology ; Trak Star Maximum Power Point Tracking (MPPT) Charge Controller	
VIII	Operating temperature – 40°C to +60°C	
IX	Warranty Period ; Minimum 5 Years	

**j) Hatari/Warning/Danger signs**

- i) Shall be made of UV protected material
- ii) Size 247mmx147mmx3mm
- iii) Color shall be bright yellow
- iv) Inscription written in black “ELECTRIC FENCE”
- v) Eligible with lettering not less than 25mm in height
- vi) A legal requirement for all electric installations

**k) Joint Clamp**

- i) Shall be made of Aluminum or Mild steel.
- ii) Shall have zinc coating of not less than 500gm/Sqm)
- iii) Kenya Bureau of Standards Test Certificate required. (iv) With space for wire grip
- iv) L-shaped
- v) Size 28mmx25mmx20mm (WHD)

**l) Barbed Wire**

Shall be:

- i) Heavily galvanized
- ii) 25Kg Roll.

**m) Cut out switch for electric fencing**

Shall be:

- i) Single live wire

## Specifications for Electric Fence

---

- ii) Shall have a Turn ON/OFF selector
- iii) Must have protected contacts to eliminate shocks.
- iv) Shall be weather proof and fully sealed.
- v) Shall be made of UV stabilized plastic
- vi) Shall have electrical contacts to handle over 10,000 Volts

### n) Multi-Units

Shall be:

- i) 3600mm diameter
- ii) Round and Veraval
- iii) 0.5mm thick sides and roof material respectively.

### o) Digital voltmeter

Shall be:

- i) Electric Fence Digital Voltmeter.
- ii) Sealed and water proof.
- iii) Made of Polycarbonate case
- iv) Capable of displaying voltage increments along the fence line
- v) Capable of displaying High Voltage pulse voltage.
- vi) Shall Auto turn -On
- vii) Capable of displaying low battery condition
- viii) Able to measure earth voltages
- ix) Has replaceable lead (1Meter) and clips
- x) Size 66mm x 125mm x 25mm

### p) Fencing pliers

Shall be:

- i) Side cutting pliers
- ii) Shall be insulated to prevent shock
- iii) Shall have “side by side” jaws with wire grip groove.
- iv) Size 215mm x 70mm x 25mm

### q) Lead wire (Under gate cables)

- i) Shall be double insulated in tough polyethylene insulating material
- ii) Shall have a lead wire of 2.5mm diameter
- iii) Shall have a lead wire of copper or aluminum.
- iv) Shall have resistance of less than 350 ohms per km
- v) Insulator should be greater than 20Kv

**DRAWINGS FOR CONSTRUCTION OF  
ELECTRIC PERIMETER FENCE FOR  
KAPCHUMBE FOREST BLOCK IN BOMET  
COUNTY**

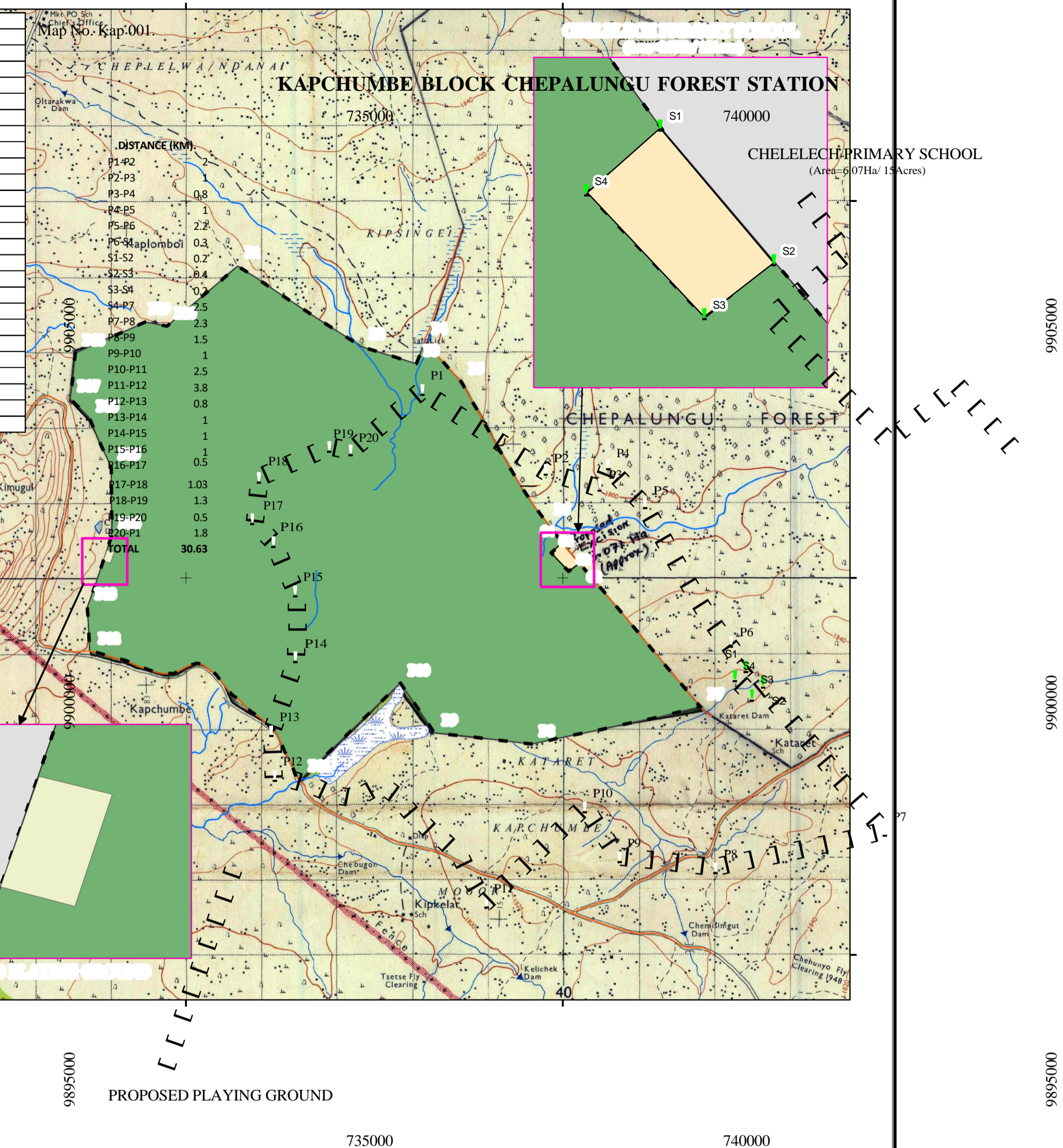

LEGEND	SCALE & DIRECTION	DATA SOURCE	PREPARED BY
RIVER ROAD PROPOSED FENCE (Length= 30.63Km Approx.) SCHOOL (Length= 6.07Ha Approx.)	  1:50,000  Meters 0 300 600 1,200 1,800 2,400	BOUNDARY PLAN  TOPO SHEET No. 131/3  GROUND SURVEY  DATUM: ARC1960  PROJECTION: UTM ZONE 36S	KENYA FOREST SERVICE  SURVEY AND MAPPING  P.O BOX 30513-00100  NAIROBI





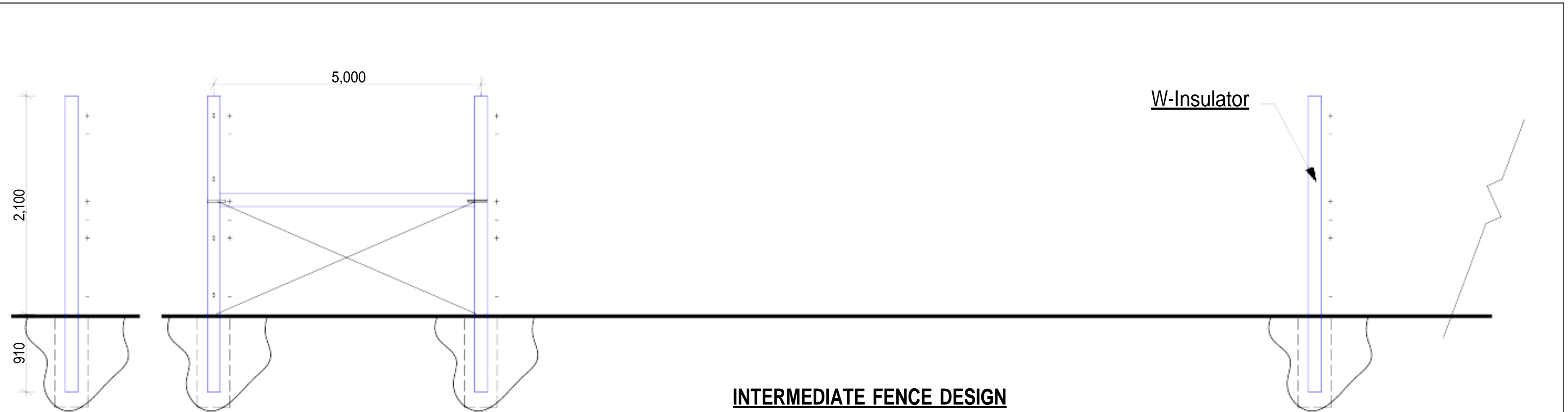

**END ELEVATION**

**INTERMEDIATE FENCE DESIGN**

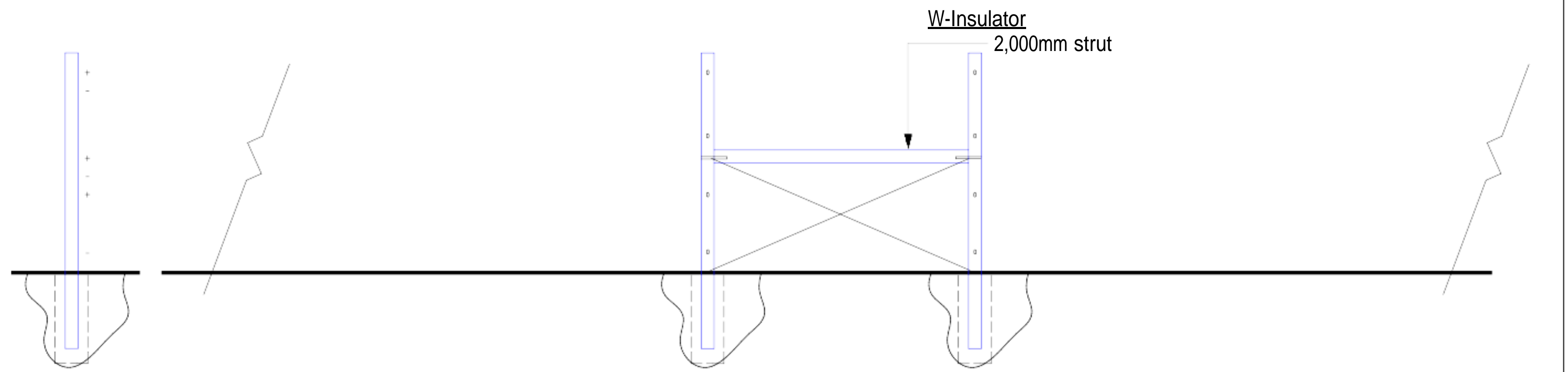

**END ELEVATION**

**LINE STRAINER ASSEMBLY**

drg. 01

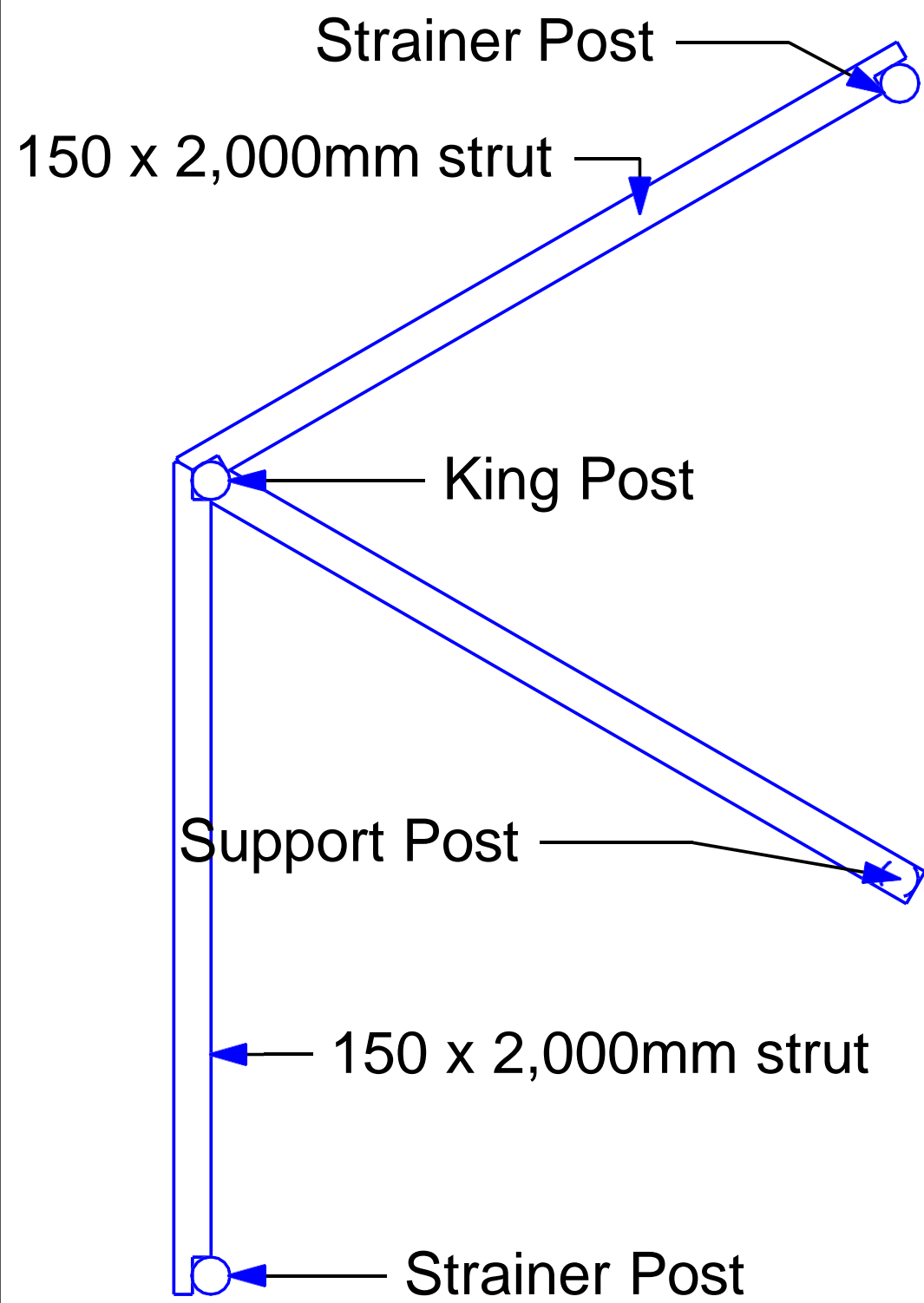

**CORNER STRAINER ASSEMBLY PLAN**

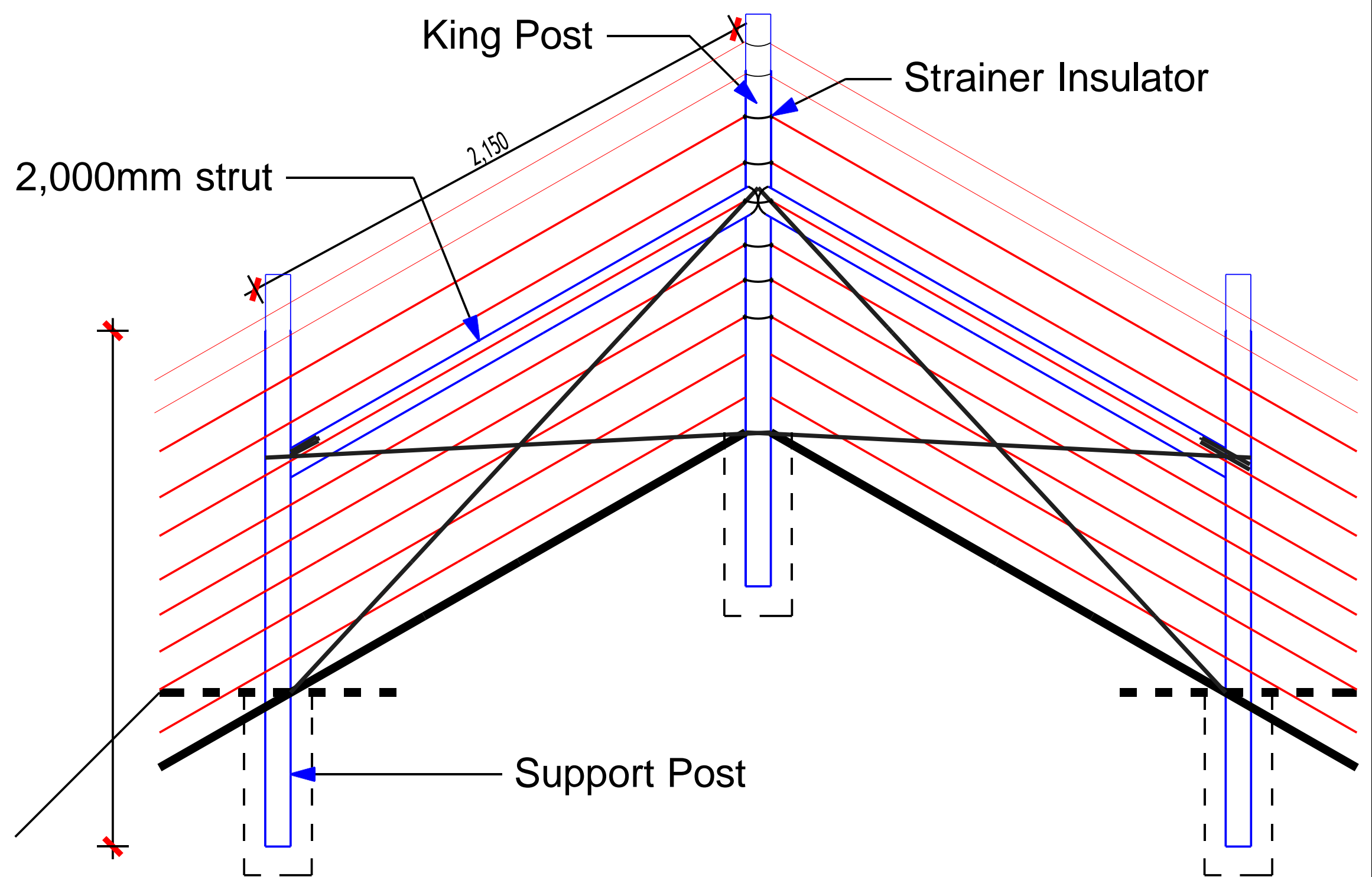

**CORNER STRAINER ASSEMBLY**

**drg. 02**

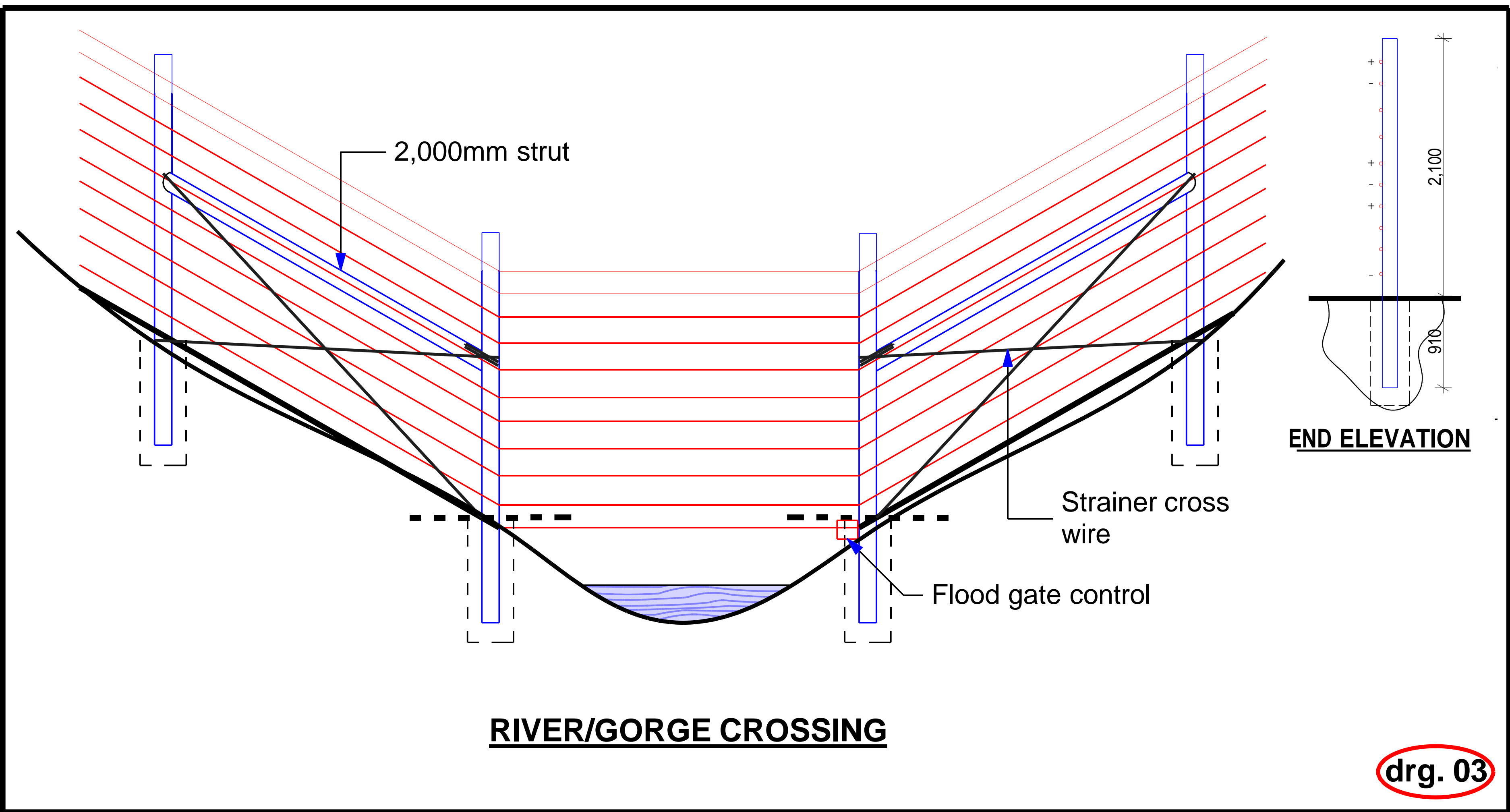

**RIVER/GORGE CROSSING**

**drg. 03**

**Supplementary Information**

---

## **PART 3 – Conditions of Contract and Contract Forms**



## Section VII. General Conditions (GC)

These **General Conditions (GC)**, read in conjunction with the **Particular Conditions (PC)** and other documents listed therein, should be a complete document expressing fairly the rights and obligations of both parties.

These **General Conditions** have been developed on the basis of considerable international experience in the drafting and management of contracts, bearing in mind a trend in the construction industry towards simpler, more straightforward language.

The **GC** can be used for both smaller admeasurement contracts and lump sum contracts.

## Table of Clauses

<b>1</b>	<b>General Provisions .....</b>	<b>95</b>
1.1	Definitions .....	95
1.2	Interpretation .....	98
1.3	Communications.....	99
1.4	Law and Language .....	99
1.5	Priority of Documents .....	100
1.6	Contract Agreement .....	100
1.7	Assignment.....	100
1.8	Care and Supply of Documents.....	100
1.9	Confidential Details .....	101
1.10	Compliance with Laws.....	101
1.11	Joint and Several Liability.....	102
1.12	Inspections and Audit by the Bank .....	102
1.13	Project Manager’s Decisions.....	102
1.14	Delegation .....	103
1.15	Subcontracting.....	103
1.16	Personnel and Equipment.....	103
1.17	Other Contractors .....	103
1.18	Employer’s and Contractor’s Risks.....	103
1.19	Employer’s Risks .....	103
1.20	Contractor’s Risks .....	104
1.21	Insurance .....	104
1.22	Site Investigation Reports .....	105
1.23	Contractors to Construct the Works .....	105
1.24	The Works to Be Completed by the Intended Completion Date.....	105
1.25	Approval by the Project Manager .....	105
1.26	Safety.....	106
1.27	Discoveries .....	106
1.28	Possession of the Site .....	106
1.29	Access to the Site .....	106
1.30	Instructions .....	106
1.31	Appointment of the Adjudicator .....	106
1.32	Procedure for Disputes .....	107
<b>2</b>	<b>Time Control .....</b>	<b>107</b>
2.1	Programme .....	107
2.2	Extension of the Intended Completion Date .....	108
2.3	Acceleration .....	108
2.4	Delays Ordered by the Project Manager .....	108
2.5	Management Meetings .....	108
2.6	Early Warning .....	109



---

<b>3 Quality Control.....</b>	<b>109</b>
3.1 Identifying Defects .....	109
3.2 Tests .....	109
3.3 Correction of Defects .....	109
3.4 Uncorrected Defects.....	109
<b>4 Cost Control.....</b>	<b>109</b>
4.1 Contract Price.....	109
4.2 Changes in the Contract Price .....	110
4.3 Variations .....	110
4.4 Cash Flow Forecasts.....	111
4.5 Payment Certificates.....	111
4.6 Payments .....	112
4.7 Compensation Events.....	112
4.8 Tax.....	113
4.9 Currencies.....	114
4.10 Price Adjustment .....	114
4.11 Retention .....	115
4.12 Liquidated Damages.....	115
4.13 Bonus .....	115
4.14 Advance Payment.....	115
4.15 Securities .....	116
4.16 Dayworks .....	116
4.17 Cost of Repairs.....	116
<b>5 Staff and Labour .....</b>	<b>116</b>
5.1 Forced Labour .....	116
5.2 Child Labour .....	117
5.3 Workers' Organizations .....	117
5.4 Non-Discrimination and Equal Opportunity .....	117
<b>6 Force Majeure .....</b>	<b>118</b>
6.1 Definition of Force Majeure.....	118
6.2 Notice of Force Majeure .....	118
6.3 Duty to Minimise Delay.....	119
6.4 Consequences of Force Majeure .....	119
6.5 Force Majeure Affecting Subcontractor .....	119
6.6 Optional Termination, Payment and Release.....	119
6.7 Release from Performance .....	120
<b>7 Finishing the Contract .....</b>	<b>121</b>
7.1 Completion .....	121
7.2 Taking Over.....	121

---

7.3	Final Account .....	121
7.4	Operating and Maintenance Manuals.....	121
7.5	Termination .....	121
7.6	Fraud and Corruption .....	122
7.7	Payment upon Termination .....	123
7.8	Property .....	124
7.9	Release from Performance .....	124
7.10	Suspension of Bank Financing .....	124
7.11	Eligibility.....	124

## Section VII. General Conditions

[Name of Employer] \_\_\_\_\_

[Name of Contract] \_\_\_\_\_

These **General Conditions (GC)**, read in conjunction with the **Particular Conditions (PC)** and other documents listed therein, constitute a complete document expressing the rights and obligations of the parties.

These **GC** can be used for both smaller admeasurement contracts and lump sum contracts.

### 1. General Provisions

#### 1.1 Definitions

In the Conditions of Contract (“these Conditions”), which include **Particular Conditions**, and these **General Conditions**, the following words and expressions shall have the meanings stated. Words indicating persons or parties include corporations and other legal entities, except where the context requires otherwise.

##### 1.1.1 The Contract

1.1.1.1 “Contract” means the Contract Agreement, the Letter of Acceptance, the Letter of Bid, these Conditions, the Specification, the Schedules, and the further documents (if any) which are listed in the Contract Agreement or in the Letter of Acceptance.

1.1.1.2 “Contract Agreement” means the contract agreement referred to in **GC** Clause 1.6 [Contract Agreement].

1.1.1.3 “Letter of Acceptance” means the letter of formal acceptance, signed by the Employer, of the Letter of Bid, including any annexed memoranda comprising agreements between and signed by both Parties. If there is no such letter of acceptance, the expression “Letter of Acceptance” means the Contract Agreement and the date of issuing or receiving the Letter of Acceptance means the date of signing the Contract Agreement.

1.1.1.4 “Letter of Bid” means the document entitled letter of bid, which was completed by the Contractor and includes the signed offer to the Employer for the Works.

1.1.1.5 “Specification” means the document entitled specification, as included in the Contract, and any additions and modifications to the specification in accordance with the Contract. Such document specifies the Works.

- 1.1.1.6 “Drawings” means the drawings of the Works, as included in the Contract, and any additional and modified drawings issued by (or on behalf of) the Employer in accordance with the Contract.
- 1.1.1.7 “Schedules” means the document(s) entitled schedules, completed by the Contractor and submitted with the Letter of Bid, as included in the Contract. Such document may include the Bill of Quantities, data, lists, and schedules of rates and/or prices.
- 1.1.1.8 The Activity Schedule is a schedule of the activities comprising the construction, installation, testing, and commissioning of the Works in a lump sum contract. It includes a lump sum price for each activity, which is used for valuations and for assessing the effects of Variations and Compensation Events.
- 1.1.1.10 “Bid” means the Letter of Bid and all other documents which the Contractor submitted with the Letter of Bid, as included in the Contract.
- 1.1.1.11 **PC means Particular Conditions**
- 1.1.2 Parties and Persons**
- 1.1.2.1 “Party” means the Employer or the Contractor, as the context requires.
- 1.1.2.2 “Employer” means the person named as employer in the **Particular Conditions** and the legal successors in title to this person.
- 1.1.2.3 “Contractor” means the person(s) named as contractor in the Letter of Bid accepted by the Employer and the legal successors in title to this person(s).
- 1.1.2.4 “Project Manager” is the person named in the **PC** (or any other competent person appointed by the Employer and notified to the Contractor, to act in replacement of the Project Manager) who is responsible for supervising the execution of the Works and administering the Contract.
- 1.1.2.5 “Subcontractor” means any person named in the Contract as a subcontractor, or any person appointed as a subcontractor, for a part of the Works; and the legal successors in title to each of these persons.
- 1.1.2.6 “Bank” means the financing institution (if any) named in the **PC**.
- 1.1.2.7 “Borrower” means the person (if any) named as the borrower in the **PC**.
- 1.1.2.8 The “Adjudicator” is the person appointed jointly by the Employer and the Contractor to resolve disputes in the first instance, as provided for in **GC** Clause 1.32.
- 1.1.3 Dates, Tests, Periods and Completion**
- 1.1.3.1 “Base Date” means the date 28 days prior to the latest date for submission of the Bid.
- 1.1.3.2 “Commencement Date” means the date notified under the **PC**.

- 1.1.3.3 “Completion Date” means the date for completion of the Works, or a Section (as the case may be) as certified by the Project Manager, in accordance with **GC** Clause 7.1.1, and as stipulated in the **PC**.
- 1.1.3.4 “Test on Completion” means the tests (if any) which are specified in the Contract and which are carried out in accordance with the Specification for the purpose of issuing the “Certificate of Completion of the Works”.
- 1.1.3.5 “Taking-Over Certificate” or “Certificate of Completion of the Works” means a certificate issued under **GC** Clause 7.1 [Completion].
- 1.1.3.6 “day” means a calendar day and “year” means 365 days.
- 1.1.3.7 “Dayworks” are varied work inputs subject to payment on a time basis for the Contractor’s employees and Equipment, in addition to payments for associated Materials and Plant.
- 1.1.4 Money and Payments**
- 1.1.4.1 “Initial Contract Amount” means the amount accepted in the Letter of Acceptance for the execution and completion of the Works and the remedying of any defects.
- 1.1.4.2 “Contract Price” means the price defined in **GC** Clause 4.1 [Contract Price], and includes adjustments in accordance with the Contract.
- 1.1.4.3 “Compensation Events” are those defined in **GC** Clause 4.7 [Compensation Events] hereunder.
- 1.1.5 Works and Goods**
- 1.1.5.1 “Contractor’s Equipment” means all apparatus, machinery, vehicles and other things required for the execution and completion of the Works and the remedying of any defects. However, Contractor’s Equipment excludes Temporary Works, Employer’s Equipment (if any), Plant, Materials and any other things intended to form or forming part of the Permanent Works.
- 1.1.5.2 “Goods” means Contractor’s Equipment, Materials, Plant and Temporary Works, or any of them as appropriate.
- 1.1.5.3 “Materials” means things of all kinds (other than Plant) intended to form or forming part of the Permanent Works, including the supply-only materials (if any) to be supplied by the Contractor under the Contract.
- 1.1.5.4 “Permanent Works” means the permanent works to be executed by the Contractor under the Contract.
- 1.1.5.5 “Plant” means the apparatus, machinery and other equipment intended to form or forming part of the Permanent Works, including vehicles purchased for the Employer and relating to the construction or operation of the Works.
- 1.1.5.6 “Section” means a part of the Works specified in the **PC** as a Section (if any).

1.1.5.7 “Temporary Works” means all temporary works of every kind (other than Contractor’s Equipment) required on Site for the execution and completion of the Permanent Works and the remedying of any defects.

1.1.5.8 “Works” mean the Permanent Works and the Temporary Works, or either of them as appropriate, and as described in the **PC**.

### **1.1.6 Other Definitions**

1.1.6.1 “Contractor’s Documents” means the calculations, computer programs and other software, drawings, manuals, models and other documents of a technical nature (if any) supplied by the Contractor under the Contract.

1.1.6.2 “Country” means the country in which the Site (or most of it) is located.

1.1.6.3 “Force Majeure” is defined in **GC** Clause 6.1 [Force Majeure].

1.1.6.4 “Laws” means all national (or state) legislation, statutes, ordinances and other laws, and regulations and by-laws of any legally constituted public authority.

1.1.6.5 “Performance Security” means the security (or securities, if any) under **GC** Clause 4.15 [Securities].

1.1.6.6 “Site” means the places where the Permanent Works are to be executed including storage and working areas and to which Plant and Materials are to be delivered, and any other places as may be specified in the **PC** as forming part of the Site.

1.1.6.8 “Unforeseeable” or “Unforeseen” means not reasonably foreseeable by an experienced Contractor by the Base Date.

1.1.6.9 “Variation” means any change to the Works, which is instructed or approved as a variation under **GC** Clause 4.3 [Variations].

### **1.2 Interpretation**

1.2.1 Interpretation In the Contract, except where the context requires otherwise:

- (a) words indicating one gender include all genders;
- (b) words indicating the singular also include the plural and words indicating the plural also include the singular;
- (c) provisions including the word “agree”, “agreed” or “agreement” require the agreement to be recorded in writing;
- (d) “written” or “in writing” means hand-written, type-written, printed or electronically made, and resulting in a permanent record;
- (e) the word “tender” is synonymous with “bid” and “tenderer” with “bidder” and the words “tender documents” with “bidding documents”.

1.2.2 The marginal words and other headings shall not be taken into consideration in the interpretation of these Conditions.

1.2.3 If sectional completion is specified in the **PC**, references in the **GC** to the Works, the Completion Date, and the Intended Completion Date apply to any Section of the Works (other than references to the Completion Date and Intended Completion Date for the whole of the Works).

### **1.3 Communications**

1.3.1 Wherever these Conditions provide for the giving or issuing of approvals, certificates, consents, determinations, notices, requests and discharges, these communications shall be:

- (a) in writing and delivered by hand (against receipt), sent by mail or courier, or transmitted using any of the agreed systems of electronic transmission as stated in the **PC**; and
- (b) delivered, sent or transmitted to the address for the recipient's communications as stated in the **PC**. However:
  - (i) if the recipient gives notice of another address, communications shall thereafter be delivered accordingly; and
  - (ii) if the recipient has not stated otherwise when requesting an approval or consent, it may be sent to the address from which the request was issued

1.3.2 Approvals, certificates, consents and determinations shall not be unreasonably withheld or delayed. When a certificate is issued to a Party, the certifier shall send a copy to the other Party.

1.3.3 When a notice is issued to a Party, by the other Party or the Project Manager, a copy shall be sent to the Project Manager or the other Party, as the case may be.

### **1.4 Law and Language**

1.4.1 The Contract shall be governed by the law of the country or other jurisdiction stated in the **PC**.

The ruling language of the Contract shall be that stated in the **PC**.

The language for communications shall be that stated in the **PC**. If no language is stated there, the language for communications shall be the ruling language of the Contract.

1.4.2 Supporting documents and printed literature that are part of the Contract may be in another language provided they are accompanied by an accurate translation of the relevant passages in the language specified, in which case, for purposes of interpretation of the Contract, this translation shall govern.

The Contractor shall bear all costs of translation to the governing language and all risks of the accuracy of such translation, for documents provided by the Contractor.

## **1.5 Priority of Documents**

1.5.1 The documents forming the Contract are to be taken as mutually explanatory of one another. For the purposes of interpretation, the priority of the documents shall be in accordance with the following sequence:

- (a) the Contract Agreement (if any),
- (b) the Letter of Acceptance,
- (c) the Bid,
- (d) the Particular Conditions
- (e) these General Conditions,
- (f) the Specification,
- (g) the Drawings, and
- (h) the Schedules and any other documents forming part of the Contract.

1.5.2 If an ambiguity or discrepancy is found in the documents, the Project Manager shall issue any necessary clarification or instruction.

## **1.6 Contract Agreement**

1.6.1 The Parties shall enter into a Contract Agreement within 28 days after the Contractor receives the Letter of Acceptance, unless the **Particular Conditions** establish otherwise. The Contract Agreement shall be based upon the relevant form provided in Section IX, Contract Forms. The costs of stamp duties and similar charges (if any) imposed by law in connection with entry into the Contract Agreement shall be borne by the Employer.

## **1.7 Assignment**

1.7.1 Neither Party shall assign the whole or any part of the Contract or any benefit or interest in or under the Contract. However, either Party:

- (a) may assign the whole or any part with the prior agreement of the other Party, at the sole discretion of such other Party, and
- (b) may, as security in favour of a bank or financial institution, assign its right to any moneys due, or to become due, under the Contract.

## **1.8 Care and Supply of Documents**



- 1.8.1 The Specification and Drawings shall be in the custody and care of the Employer. Unless otherwise stated in the Contract, two copies of the Contract and of each subsequent Drawing shall be supplied to the Contractor, who may make or request further copies at the cost of the Contractor.
- 1.8.2 Each of the Contractor's Documents shall be in the custody and care of the Contractor, unless and until taken over by the Employer. Unless otherwise stated in the Contract, the Contractor shall supply to the Project Manager six copies of each of the Contractor's Documents.
- 1.8.3 The Contractor shall keep, on the Site, a copy of the Contract, publications named in the Specification, the Contractor's Documents (if any), the Drawings and Variations and other communications given under the Contract. The Employer's Personnel shall have the right of access to all these documents at all reasonable times.
- 1.8.4 If a Party becomes aware of an error or defect in a document which was prepared for use in executing the Works, the Party shall promptly give notice to the other Party of such error or defect.

## **1.9 Confidential Details**

- 1.9.1 The Contractor's and the Employer's Personnel shall disclose all such confidential and other information as may be reasonably required in order to verify the Contractor's compliance with the Contract and allow its proper implementation.

Each of them shall treat the details of the Contract as private and confidential, except to the extent necessary to carry out their respective obligations under the Contract or to comply with applicable Laws. Each of them shall not publish or disclose any particulars of the Works prepared by the other Party without the previous agreement of the other Party. However, the Contractor shall be permitted to disclose any publicly available information, or information otherwise required to establish his qualifications to compete for other projects.

- 1.9.2 Notwithstanding the above, the Contractor may furnish to its Subcontractor(s) such documents, data and other information it receives from the Employer to the extent required for the Subcontractor(s) to perform its work under the Contract, in which event the Contractor shall obtain from such Subcontractor(s) an undertaking of confidentiality similar to that imposed on the Contractor under this Clause.

## **1.10 Compliance with Laws**

- 1.10.1 The Contractor shall, in performing the Contract, comply with applicable Laws.
- 1.10.2 Unless otherwise stated in the **Particular Conditions**:

- (a) the Employer shall acquire and pay for all permits, approvals and/or licenses from all local, state or national government authorities or public service undertakings in the Employer's Country, which (i) such authorities or undertakings require the Employer to obtain in the Employer's name, and (ii) are necessary for the execution of the Contract, including those required for the performance by both the Contractor and the Employer of their respective obligations under the Contract;
- (b) the Contractor shall acquire and pay for all permits, approvals and/or licenses from all local, state or national government authorities or public service undertakings in the Employer's Country, which such authorities or undertakings require the Contractor to obtain in its name and which are necessary for the performance of the Contract, including, without limitation, visas for the Contractor's and Subcontractor's personnel and entry permits for all imported Contractor's Equipment. The Contractor shall acquire all other permits, approvals and/or licenses that are not the responsibility of the Employer under GC Clause 1.10.2(a) hereof and that are necessary for the performance of the Contract. The Contractor shall indemnify and hold harmless the Employer from and against any and all liabilities, damages, claims, fines, penalties and expenses of whatever nature arising or resulting from the violation of such laws by the Employer or its personnel, including the Subcontractors and their personnel, but without prejudice to GC Clause 1.10.1 hereof.

### **1.11 Joint and Several Liability**

- 1.11.1 If the Contractor is a joint venture, consortium, or association (JVCA) of two or more persons, all such persons shall be jointly and severally bound to the Employer for the fulfilment of the provisions of the Contract, unless otherwise specified in the PC, and shall designate one of such persons to act as a leader with authority to bind the JVCA. The composition or the constitution of the JVCA shall not be altered without the prior consent of the Employer.

### **1.12 Inspections and Audit by the Bank**

- 1.12.1 The Contractor shall permit the Bank and/or persons appointed by the Bank to inspect the Site and/or the Contractor's accounts and records relating to the performance of the Contract and to have such accounts and records audited by auditors appointed by the Bank if required by the Bank.
- 1.12.2 The Contractor shall maintain all documents and records related to the Contract for a period of three (3) years after completion of the Works. The Contractor shall provide any documents necessary for the investigation of allegations of fraud, collusion, coercion, or corruption and require its employees or agents with knowledge of the Contract to respond to questions from the Bank.

### **1.13 Project Manager's Decisions**

1.13.1 Except where otherwise specifically stated, the Project Manager shall decide contractual matters between the Employer and the Contractor in the role representing the Employer.

**1.14 Delegation**

1.14.1 The Project Manager may delegate any of his duties and responsibilities and may cancel any delegation after notifying the Contractor.

**1.15 Subcontracting**

1.15.1 The Contractor may subcontract with the approval of the Project Manager, but may not assign the Contract without the approval of the Employer in writing. Subcontracting shall not alter the Contractor's obligations.

**1.16 Personnel and Equipment**

1.16.1 The Contractor shall employ the key personnel and use the equipment identified in its Bid, to carry out the Works or other personnel and equipment approved by the Project Manager. The Project Manager shall approve any proposed replacement of key personnel and equipment only if their relevant qualifications or characteristics are substantially equal to or better than those proposed in the Bid.

1.16.2 If the Project Manager asks the Contractor to remove a person who is a member of the Contractor's staff or work force, stating the reasons, the Contractor shall ensure that the person leaves the Site within seven days and has no further connection with the work in the Contract.

**1.17 Other Contractors**

1.17.1 The Contractor shall cooperate and share the Site with other contractors, public authorities, utilities, and the Employer between the dates given in the Schedule of Other Contractors, as referred to in the **PC**. The Contractor shall also provide facilities and services for them as described in the Schedule. The Employer may modify the Schedule of Other Contractors, and shall notify the Contractor of any such modification.

**1.18 Employer's and Contractor's Risks**

1.18.1 The Employer carries the risks which this Contract states are Employer's risks, and the Contractor carries the risks which this Contract states are Contractor's risks.

**1.19 Employer's Risks**

- 1.19.1 From the Start Date until the Defects Liability Certificate has been issued, the following are Employer's risks:
- (a) The risk of personal injury, death, or loss of or damage to property (excluding the Works, Plant, Materials, and Equipment), which are due to
    - (i) use or occupation of the Site by the Works or for the purpose of the Works, which is the unavoidable result of the Works or
    - (ii) negligence, breach of statutory duty, or interference with any legal right by the Employer or by any person employed by or contracted to him except the Contractor.
  - (b) The risk of damage to the Works, Plant, Materials, and Equipment to the extent that it is due to a fault of the Employer or in the Employer's design, or due to war or radioactive contamination directly affecting the country where the Works are to be executed.
- 1.19.2 From the Completion Date until the Defects Liability Certificate has been issued, the risk of loss of or damage to the Works, Plant, and Materials is an Employer's risk except loss or damage due to
- (a) a Defect which existed on the Completion Date,
  - (b) an event occurring before the Completion Date, which was not itself an Employer's risk, or
  - (c) the activities of the Contractor on the Site after the Completion Date.

## **1.20 Contractor's Risks**

- 1.20.1 From the Starting Date until the Defects Liability Certificate has been issued, the risks of personal injury, death, and loss of or damage to property (including, without limitation, the Works, Plant, Materials, and Equipment) which are not Employer's risks are Contractor's risks.

## **1.21 Insurance**

- 1.21.1 The Contractor shall provide, in the joint names of the Employer and the Contractor, insurance cover from the Start Date to the end of the Defects Liability Period, in the amounts and deductibles stated in the **PC** for the following events which are due to the Contractor's risks:
- (a) loss of or damage to the Works, Plant, and Materials;
  - (b) loss of or damage to Equipment;
  - (c) loss of or damage to property (except the Works, Plant, Materials, and Equipment) in connection with the Contract; and
  - (d) personal injury or death.

- 1.21.2 Policies and certificates for insurance shall be delivered by the Contractor to the Project Manager for the Project Manager's approval before the Commencement Date. All such insurance shall provide for compensation to be payable in the types and proportions of currencies required to rectify the loss or damage incurred.
- 1.21.3 If the Contractor does not provide any of the policies and certificates required, the Employer may effect the insurance which the Contractor should have provided and recover the premiums the Employer has paid from payments otherwise due to the Contractor or, if no payment is due, the payment of the premiums shall be a debt due.
- 1.21.4 Alterations to the terms of insurance shall not be made without the approval of the Project Manager.
- 1.21.5 Both parties shall comply with any conditions of the insurance policies.
- 1.22 Site Investigation Reports**
- 1.22.1 The Contractor, in preparing the Bid, shall rely on any Site Investigation Reports referred to in the PC, supplemented by any information available to the Bidder.
- 1.23 Contractors to Construct the Works**
- 1.23.1 The Contractor shall construct and install the Works in accordance with the Specifications and Drawings.
- 1.24 The Works to Be Completed by the Intended Completion Date**
- 1.24.1 The Contractor may commence execution of the Works on the Start Date and shall carry out the Works in accordance with the Program submitted by the Contractor, as updated with the approval of the Project Manager, and complete them by the Intended Completion Date.
- 1.25 Approval by the Project Manager**
- 1.25.1 The Contractor shall submit Specifications and Drawings showing the proposed Temporary Works to the Project Manager, who is to approve them if they comply with the Specifications and Drawings.
- 1.25.2 The Contractor shall be responsible for design of Temporary Works.
- 1.25.3 The Project Manager's approval shall not alter the Contractor's responsibility for design of the Temporary Works.
- 1.25.4 The Contractor shall obtain approval of third parties to the design of the Temporary Works, where required.

1.25.5 All Drawings prepared by the Contractor for the execution of the temporary or permanent Works, are subject to prior approval by the Project Manager before this use.

**1.26 Safety**

1.26.1 The Contractor shall be responsible for the safety of all activities on the Site.

**1.27 Discoveries**

1.27.1 Anything of historical or other interest or of significant value unexpectedly discovered on the Site shall be the property of the Employer. The Contractor shall notify the Project Manager of such discoveries and carry out the Project Manager's instructions for dealing with them.

**1.28 Possession of the Site**

1.28.1 The Employer shall give possession of all parts of the Site to the Contractor. If possession of a part is not given by the date stated in the **PC**, the Employer shall be deemed to have delayed the start of the relevant activities, and this shall be a Compensation Event.

**1.29 Access to the Site**

1.29.1 The Contractor shall allow the Project Manager and any person authorized by the Project Manager access to the Site and to any place where work in connection with the Contract is being carried out or is intended to be carried out.

**1.30 Instructions**

1.30.1 The Contractor shall carry out all instructions of the Project Manager which comply with the applicable laws where the Site is located.

**1.31 Appointment of the Adjudicator**

1.31.1 The Adjudicator shall be appointed jointly by the Employer and the Contractor, at the time of the Employer's issuance of the Letter of Acceptance. If, in the Letter of Acceptance, the Employer does not agree on the appointment of the Adjudicator, the Employer will request the Appointing Authority designated in the **PC**, to appoint the Adjudicator within 14 days of receipt of such request.

- 1.31.2 Should the Adjudicator resign or die, or should the Employer and the Contractor agree that the Adjudicator is not functioning in accordance with the provisions of the Contract, a new Adjudicator shall be jointly appointed by the Employer and the Contractor. In case of disagreement between the Employer and the Contractor, within 30 days, the Adjudicator shall be designated by the Appointing Authority designated in the **PC** at the request of either party, within 14 days of receipt of such request.

### **1.32 Procedure for Disputes**

- 1.32.1 If the Contractor believes that a decision taken by the Project Manager was either outside the authority given to the Project Manager by the Contract or that the decision was wrongly taken, the decision shall be referred to the Adjudicator within 14 days of the notification of the Project Manager's decision.
- 1.32.2 The Adjudicator shall give a decision in writing within 28 days of receipt of a notification of a dispute.
- 1.32.3 The Adjudicator shall be paid by the hour at the rate specified in the **PC**, together with reimbursable expenses of the types specified in the **PC**, and the cost shall be divided equally between the Employer and the Contractor, whatever decision is reached by the Adjudicator. Either party may refer a decision of the Adjudicator to an Arbitrator within 28 days of the Adjudicator's written decision. If neither party refers the dispute to arbitration within the above 28 days, the Adjudicator's decision shall be final and binding.
- 1.32.4 The arbitration shall be conducted in accordance with the arbitration procedures published by the institution named and in the place specified in the **PC**.

## **2. Time Control**

### **2.1 Programme**

- 2.1.1 Within the time stated in the **PC**, after the date of the Letter of Acceptance, the Contractor shall submit to the Project Manager for approval a Programme showing the general methods, arrangements, order, and timing for all the activities in the Works. In the case of a lump sum contract, the activities in the Programme shall be consistent with those in the Activity Schedule.
- 2.1.2 An update of the Programme shall be a program showing the actual progress achieved on each activity and the effect of the progress achieved on the timing of the remaining work, including any changes to the sequence of the activities.
- 2.1.3 The Contractor shall submit to the Project Manager for approval an updated Programme at intervals no longer than the period stated in the **PC**. If the Contractor does not submit an updated Programme within this period, the Project Manager may withhold the amount stated in the **PC** from the next payment certificate and continue to withhold this amount until the next payment after the date on which the overdue Programme has been submitted. In the case

of a lump sum contract, the Contractor shall provide an updated Activity Schedule within 14 days of being instructed to by the Project Manager.

- 2.1.4 The Project Manager's approval of the Programme shall not alter the Contractor's obligations. The Contractor may revise the Programme and submit it to the Project Manager again at any time. A revised Programme shall show the effect of Variations and Compensation Events.

## **2.2 Extension of the Intended Completion Date**

- 2.2.1 The Project Manager shall extend the Intended Completion Date if a Compensation Event occurs or a Variation is issued which makes it impossible for Completion to be achieved by the Intended Completion Date without the Contractor taking steps to accelerate the remaining work, which would cause the Contractor to incur additional cost.

- 2.2.2 The Project Manager shall decide whether and by how much to extend the Intended Completion Date within 21 days of the Contractor asking the Project Manager for a decision upon the effect of a Compensation Event or Variation and submitting full supporting information. If the Contractor has failed to give early warning of a delay or has failed to cooperate in dealing with a delay, the delay by this failure shall not be considered in assessing the new Intended Completion Date.

## **2.3 Acceleration**

- 2.3.1 When the Employer wants the Contractor to finish before the Intended Completion Date, the Project Manager shall obtain priced proposals for achieving the necessary acceleration from the Contractor. If the Employer accepts these proposals, the Intended Completion Date shall be adjusted accordingly and confirmed by both the Employer and the Contractor.

- 2.3.2 If the Contractor's priced proposals for acceleration are accepted by the Employer, they are incorporated in the Contract Price and treated as a Variation.

## **2.4 Delays Ordered by the Project Manager**

- 2.4.1 The Project Manager may instruct the Contractor to delay the start or progress of any activity within the Works.

## **2.5 Management Meetings**

- 2.5.1 Either the Project Manager or the Contractor may require the other to attend a management meeting. The business of a management meeting shall be to review the plans for remaining work and to deal with matters raised in accordance with the early warning procedure.

- 2.5.2 The Project Manager shall record the business of management meetings and provide copies of the record to those attending the meeting and to the Employer. The responsibility of the parties for actions to be taken shall be decided by the Project Manager either at the management meeting or after the management meeting and stated in writing to all who attended the meeting.



## **2.6 Early Warning**

- 2.6.1 The Contractor shall warn the Project Manager at the earliest opportunity of specific likely future events or circumstances that may adversely affect the quality of the work, increase the Contract Price, or delay the execution of the Works. The Project Manager may require the Contractor to provide an estimate of the expected effect of the future event or circumstance on the Contract Price and Completion Date. The estimate shall be provided by the Contractor as soon as reasonably possible.
- 2.6.2 The Contractor shall cooperate with the Project Manager in making and considering proposals for how the effect of such an event or circumstance can be avoided or reduced by anyone involved in the work and in carrying out any resulting instruction of the Project Manager.

## **3. Quality Control**

### **3.1 Identifying Defects**

- 3.1.1 The Project Manager shall check the Contractor's work and notify the Contractor of any Defects that are found. Such checking shall not affect the Contractor's responsibilities. The Project Manager may instruct the Contractor to search for a Defect and to uncover and test any work that the Project Manager considers may have a Defect.

### **3.2 Tests**

- 3.2.1 If the Project Manager instructs the Contractor to carry out a test not specified in the Specification to check whether any work has a Defect and the test shows that it does, the Contractor shall pay for the test and any samples. If there is no Defect, the test shall be a Compensation Event.

### **3.3 Correction of Defects**

- 3.3.1 The Project Manager shall give notice to the Contractor of any Defects before the end of the Defects Liability Period, which begins at Completion, and is defined in the **PC**. The Defects Liability Period shall be extended for as long as Defects remain to be corrected.

Every time notice of a Defect is given, the Contractor shall correct the notified Defect within the length of time specified by the Project Manager's notice.

### **3.4 Uncorrected Defects**

- 3.4.1 If the Contractor has not corrected a Defect within the time specified in the Project Manager's notice, the Project Manager shall assess the cost of having the Defect corrected, and the Contractor shall pay this amount.

## **4. Cost Control**

### **4.1 Contract Price**

4.1.1 In the case of an admeasurement contract, the Bill of Quantities shall contain priced items for the Works to be performed by the Contractor. The Bill of Quantities is used to calculate the Contract Price. The Contractor will be paid for the quantity of the work accomplished at the rate in the Bill of Quantities for each item.

4.1.2 In the case of a lump sum contract, the Activity Schedule shall contain the priced activities for the Works to be performed by the Contractor. The Activity Schedule is used to monitor and control the performance of activities on which basis the Contractor will be paid. If payment for Materials on Site shall be made separately, the Contractor shall show delivery of Materials to the Site separately on the Activity Schedule.

## **4.2 Changes in the Contract Price**

4.2.1 In the case of an admeasurement contract:

- (a) If the final quantity of the work done differs from the quantity in the Bill of Quantities for the particular item by more than 25 percent, provided the change exceeds 1 percent of the Initial Contract Price, the Project Manager shall adjust the rate to allow for the change.
- (b) The Project Manager shall not adjust rates from changes in quantities if thereby the Initial Contract Price is exceeded by more than 15 percent, except with the prior approval of the Employer.
- (c) If requested by the Project Manager, the Contractor shall provide the Project Manager with a detailed cost breakdown of any rate in the Bill of Quantities.

4.2.2 In the case of a lump sum contract, the Activity Schedule shall be amended by the Contractor to accommodate changes of Programme or method of working made at the Contractor's own discretion. Prices in the Activity Schedule shall not be altered when the Contractor makes such changes to the Activity Schedule.

## **4.3 Variations**

4.3.1 All Variations shall be included in updated Programs, and, in the case of a lump sum contract, also in the Activity Schedule, produced by the Contractor.

4.3.2 The Contractor shall provide the Project Manager with a quotation for carrying out the Variation when requested to do so by the Project Manager. The Project Manager shall assess the quotation, which shall be given within seven (7) days of the request or within any longer period stated by the Project Manager and before the Variation is ordered.

- 4.3.3 If the Contractor's quotation is unreasonable, the Project Manager may order the Variation and make a change to the Contract Price, which shall be based on the Project Manager's own forecast of the effects of the Variation on the Contractor's costs.
- 4.3.4 If the Project Manager decides that the urgency of varying the work would prevent a quotation being given and considered without delaying the work, no quotation shall be given and the Variation shall be treated as a Compensation Event.
- 4.3.5 The Contractor shall not be entitled to additional payment for costs that could have been avoided by giving early warning.
- 4.3.6 In the case of an admeasurement contract, if the work in the Variation corresponds to an item description in the Bill of Quantities and if, in the opinion of the Project Manager, the quantity of work above the limit stated in GC Clause 4.2.1 or the timing of its execution do not cause the cost per unit of quantity to change, the rate in the Bill of Quantities shall be used to calculate the value of the Variation. If the cost per unit of quantity changes, or if the nature or timing of the work in the Variation does not correspond with items in the Bill of Quantities, the quotation by the Contractor shall be in the form of new rates for the relevant items of work.
- 4.4 Cash Flow Forecasts**
- 4.4.1 When the Program, or, in the case of a lump sum contract, the Activity Schedule, is updated, the Contractor shall provide the Project Manager with an updated cash flow forecast. The cash flow forecast shall include different currencies, as defined in the Contract, converted as necessary using the Contract exchange rates.
- 4.5 Payment Certificates**
- 4.5.1 The Contractor shall submit to the Project Manager monthly statements of the estimated value of the work executed less the cumulative amount certified previously.
- 4.5.2 The Project Manager shall check the Contractor's monthly statement and certify the amount to be paid to the Contractor.
- 4.5.3 The value of work executed shall be determined by the Project Manager.
- 4.5.4 The value of work executed shall comprise:
- (a) In the case of an admeasurement contract, the value of the quantities of work in the Bill of Quantities that have been completed; or
  - (b) In the case of a lump sum contract, the value of work executed shall comprise the value of completed activities in the Activity Schedule.

4.5.5 The value of work executed shall include the valuation of Variations and Compensation Events.

4.5.6 The Project Manager may exclude any item certified in a previous certificate or reduce the proportion of any item previously certified in any certificate in the light of later information.

#### **4.6 Payments**

4.6.1 Payments shall be adjusted for deductions for advance payments and retention. The Employer shall pay the Contractor the amounts certified by the Project Manager within 28 days of the date of each certificate. If the Employer makes a late payment, the Contractor shall be paid interest on the late payment in the next payment. Interest shall be calculated from the date by which the payment should have been made up to the date when the late payment is made at the prevailing rate of interest for commercial borrowing for each of the currencies in which payments are made.

4.6.2 If an amount certified is increased in a later certificate or as a result of an award by the Adjudicator or an Arbitrator, the Contractor shall be paid interest upon the delayed payment as set out in this clause. Interest shall be calculated from the date upon which the increased amount would have been certified in the absence of dispute.

4.6.3 Unless otherwise stated, all payments and deductions shall be paid or charged in the proportions of currencies comprising the Contract Price.

4.6.4 Items of the Works for which no rate or price has been entered in shall not be paid for by the Employer and shall be deemed covered by other rates and prices in the Contract.

#### **4.7 Compensation Events**

4.7.1 The following shall be Compensation Events:

- (a) The Employer does not give access to a part of the Site by the Site Possession Date pursuant to GC Clause 1.29.
- (b) The Employer modifies the Schedule of Other Contractors in a way that affects the work of the Contractor under the Contract.
- (c) The Project Manager orders a delay or does not issue Drawings, Specifications, or instructions required for execution of the Works on time.
- (d) The Project Manager instructs the Contractor to uncover or to carry out additional tests upon work, which is then found to have no Defects.
- (e) The Project Manager unreasonably does not approve a subcontract to be let.
- (f) Ground conditions are substantially more adverse than could reasonably have been assumed before issuance of the Letter of Acceptance from the

information issued to bidders (including the Site Investigation Reports), from information available publicly and from a visual inspection of the Site.

- (g) The Project Manager gives an instruction for dealing with an unforeseen condition, caused by the Employer, or additional work required for safety or other reasons.
- (h) Other contractors, public authorities, utilities, or the Employer does not work within the dates and other constraints stated in the Contract, and they cause delay or extra cost to the Contractor.
- (i) The advance payment is delayed.
- (j) The effects on the Contractor of any of the Employer's Risks.
- (k) The Project Manager unreasonably delays issuing a Certificate of Completion.

4.7.2 If a Compensation Event would cause additional cost or would prevent the work being completed before the Intended Completion Date, the Contract Price shall be increased and/or the Intended Completion Date shall be extended. The Project Manager shall decide whether and by how much the Contract Price shall be increased and whether and by how much the Intended Completion Date shall be extended.

4.7.3 As soon as information demonstrating the effect of each Compensation Event upon the Contractor's forecast cost has been provided by the Contractor, it shall be assessed by the Project Manager, and the Contract Price shall be adjusted accordingly. If the Contractor's forecast is deemed unreasonable, the Project Manager shall adjust the Contract Price based on the Project Manager's own forecast. The Project Manager shall assume that the Contractor shall react competently and promptly to the event.

4.7.4 The Contractor shall not be entitled to compensation to the extent that the Employer's interests are adversely affected by the Contractor's not having given early warning or not having cooperated with the Project Manager.

## **4.8 Tax**

4.8.1 The Project Manager shall adjust the Contract Price if taxes, duties, and other levies are changed between the date 28 days before the submission of bids for the Contract and the date of the last Completion certificate. The adjustment shall be the change in the amount of tax payable by the Contractor, provided such changes are not already reflected in the Contract Price or are a result of GC Clause 4.10.

**4.9 Currencies**

- 4.9.1 Where payments are made in currencies other than the currency of the Employer's country specified in the **PC**, the exchange rates used for calculating the amounts to be paid shall be the exchange rates stated in the Contractor's Bid.

**4.10 Price Adjustment**

- 4.10.1 Prices shall be adjusted for fluctuations in the cost of inputs only if provided for in the **PC**. If so provided, the amounts certified in each payment certificate, before deducting for Advance Payment, shall be adjusted by applying the respective price adjustment factor to the payment amounts due in each currency. A separate formula of the type indicated below applies to each Contract currency:

$$P_c = A_c + B_c \text{Imc/Ioc}$$

where:

**P<sub>c</sub>** is the adjustment factor for the portion of the Contract Price payable in a specific currency "c."

**A<sub>c</sub>** and **B<sub>c</sub>** are coefficients<sup>13</sup> specified in the **PC**, representing the nonadjustable and adjustable portions, respectively, of the Contract Price payable in that specific currency "c;" and

**Imc** is the index prevailing at the end of the month being invoiced and **Ioc** is the index prevailing 28 days before Bid opening for inputs payable; both in the specific currency "c."

- 4.10.2 If the value of the index is changed after it has been used in a calculation, the calculation shall be corrected and an adjustment made in the next payment certificate. The index value shall be deemed to take account of all changes in cost due to fluctuations in costs.

---

<sup>13</sup> The sum of the two coefficients **A<sub>c</sub>** and **B<sub>c</sub>** should be 1 (one) in the formula for each currency. Normally, both coefficients shall be the same in the formulae for all currencies, since coefficient **A**, for the nonadjustable portion of the payments, is a very approximate figure (usually 0.15) to take account of fixed cost elements or other nonadjustable components. The sum of the adjustments for each currency is added to the Contract Price.

**4.11 Retention**

- 4.11.1 The Employer shall retain from each payment due to the Contractor the proportion stated in the **PC** until Completion of the whole of the Works.
- 4.11.2 Upon the issue of a Certificate of Completion of the Works by the Project Manager, in accordance with **GC** Clause 7.1.1, half the total amount retained shall be repaid to the Contractor and half when the Defects Liability Period has passed and the Project Manager has certified that all Defects notified by the Project Manager to the Contractor before the end of this period have been corrected. The Contractor may substitute retention money with an “on demand” Bank guarantee.

**4.12 Liquidated Damages**

- 4.12.1 The Contractor shall pay liquidated damages to the Employer at the rate per day stated in the **PC** for each day that the Completion Date is later than the Intended Completion Date. The total amount of liquidated damages shall not exceed the amount defined in the **PC**. The Employer may deduct liquidated damages from payments due to the Contractor. Payment of liquidated damages shall not affect the Contractor’s liabilities.
- 4.12.2 If the Intended Completion Date is extended after liquidated damages have been paid, the Project Manager shall correct any overpayment of liquidated damages by the Contractor by adjusting the next payment certificate. The Contractor shall be paid interest on the overpayment, calculated from the date of payment to the date of repayment, at the rates specified in **GC** Clause 4.6.1.

**4.13 Bonus**

- 4.13.1 The Contractor shall be paid a Bonus calculated at the rate per calendar day stated in the **PC** for each day (less any days for which the Contractor is paid for acceleration) that the Completion is earlier than the Intended Completion Date. The Project Manager shall certify that the Works are complete, although they may not be due to be complete.

**4.14 Advance Payment**

- 4.14.1 The Employer shall make advance payment to the Contractor of the amounts stated in the **PC** by the date stated in the **PC**, against provision by the Contractor of an Unconditional Bank Guarantee in a form and by a bank acceptable to the Employer in amounts and currencies equal to the advance payment. The Guarantee shall remain effective until the advance payment has been repaid, but the amount of the Guarantee shall be progressively reduced by the amounts repaid by the Contractor. Interest shall not be charged on the advance payment.

4.14.2 The Contractor is to use the advance payment only to pay for Equipment, Plant, Materials, and mobilization expenses required specifically for execution of the Contract. The Contractor shall demonstrate that advance payment has been used in this way by supplying copies of invoices or other documents to the Project Manager.

4.14.3 The advance payment shall be repaid by deducting proportionate amounts from payments otherwise due to the Contractor, following the schedule of completed percentages of the Works on a payment basis. No account shall be taken of the advance payment or its repayment in assessing valuations of work done, Variations, price adjustments, Compensation Events, Bonuses, or Liquidated Damages.

#### **4.15 Securities**

4.15.1 The Performance Security shall be provided to the Employer no later than the date specified in the Letter of Acceptance and shall be issued in an amount specified in the PC, by a bank or surety acceptable to the Employer, and denominated in the types and proportions of the currencies in which the Contract Price is payable. The Performance Security shall be valid until a date 28 days from the date of issue of the Certificate of Completion in the case of a Bank Guarantee, and until one year from the date of issue of the Completion Certificate in the case of a Performance Bond.

#### **4.16 Dayworks**

4.16.1 If applicable, the Dayworks rates in the Contractor's Bid shall be used for small additional amounts of work only when the Project Manager has given written instructions in advance for additional work to be paid for in that way.

4.16.2 All work to be paid for as Dayworks shall be recorded by the Contractor on forms approved by the Project Manager. Each completed form shall be verified and signed by the Project Manager within two days of the work being done.

4.16.3 The Contractor shall be paid for Dayworks subject to obtaining signed Dayworks forms.

#### **4.17 Cost of Repairs**

Loss or damage to the Works or Materials to be incorporated in the Works between the Start Date and the end of the Defects Correction periods shall be remedied by the Contractor at the Contractor's cost if the loss or damage arises from the Contractor's acts or omissions.

## **5. Staff and Labour**

### **5.1 Forced Labour**



5.1.1 The Contractor shall not employ forced labour, which consists of any work or service, not voluntarily performed, that is exacted from an individual under threat of force or penalty, and includes any kind of involuntary or compulsory labour, such as indentured labour, bonded labour or similar labour-contracting arrangements.

## **5.2 Child Labour**

5.2.1 The Contractor shall not employ children in a manner that is economically exploitative, or is likely to be hazardous, or to interfere with the child's education, or to be harmful to the child's health or physical, mental, spiritual, moral, or social development. Where the relevant labour laws have provisions for employment of minors, the Contractor shall follow those laws applicable to the Contractor. Children below the age of 18 years shall not be employed in dangerous work.

## **5.3 Workers' Organizations**

5.3.1 In countries where the relevant labour laws recognize workers' rights to form and to join workers' organisations of their choosing without interference and to bargain collectively, the Contractor shall comply with such laws. Where the relevant labour laws substantially restrict workers' organisations, the Contractor shall enable alternative means for Contractor's Personnel to express their grievances and protect their rights regarding working conditions and terms of employment. In either case described above, and where the relevant labour laws are silent, the Contractor shall not discourage Contractor's Personnel from forming or joining workers' organisations of their choosing or from bargaining collectively, and shall not discriminate or retaliate against the Contractor's Personnel who participate, or seek to participate, in such organisations and bargain collectively. The Contractor shall engage with such workers representatives. Worker organisations are expected to fairly represent the workers in the workforce.

## **5.4 Non-Discrimination and Equal Opportunity**

5.4.1 The Contractor shall not make employment decisions on the basis of personal characteristics unrelated to inherent job requirements. The Contractor shall base the employment relationship on the principle of equal opportunity and fair treatment, and shall not discriminate with respect to aspects of the employment relationship, including recruitment and hiring, compensation (including wages and benefits), working conditions and terms of employment, access to training, promotion, termination of employment or retirement, and discipline. In countries where the relevant labour laws provide for non-discrimination in employment, the Contractor shall comply with such laws. When the relevant labour laws are silent on non-discrimination in employment, the Contractor shall meet this Clause's requirements. Special measures of protection or assistance to remedy past discrimination or selection for a particular job based on inherent requirements of the job shall not be deemed discrimination.

## **6. Force Majeure**

### **6.1 Definition of Force Majeure**

6.1.1 In this Clause, "Force Majeure" means an exceptional event or circumstance:

- (a) which is beyond a Party's control,
- (b) which such Party could not reasonably have provided against before entering into the Contract,
- (c) which, having arisen, such Party could not reasonably have avoided or overcome, and
- (d) which is not substantially attributable to the other Party.

Force Majeure may include, but is not limited to, exceptional events or circumstances of the kind listed below, so long as conditions (a) to (d) above are satisfied:

- (i) war, hostilities (whether war be declared or not), invasion, act of foreign enemies,
- (ii) rebellion, terrorism, sabotage by persons other than the Contractor's Personnel, revolution, insurrection, military or usurped power, or civil war,
- (iii) riot, commotion, disorder, strike or lockout by persons other than the Contractor's Personnel,
- (iv) munitions of war, explosive materials, ionising radiation or contamination by radio-activity, except as may be attributable to the Contractor's use of such munitions, explosives, radiation or radio-activity, and
- (v) natural catastrophes such as earthquake, hurricane, typhoon or volcanic activity.

### **6.2 Notice of Force Majeure**

6.2.1 If a Party is or will be prevented from performing its substantial obligations under the Contract by Force Majeure, then it shall give notice to the other Party of the event or circumstances constituting the Force Majeure and shall specify the obligations, the performance of which is or will be prevented. The notice shall be given within 14 days after the Party became aware, or should have become aware, of the relevant event or circumstance constituting Force Majeure.

6.2.2 The Party shall, having given notice, be excused performance of its obligations for so long as such Force Majeure prevents it from performing them.

6.2.3 Notwithstanding any other provision of this Clause, Force Majeure shall not apply to obligations of either Party to make payments to the other Party under the Contract

### **6.3 Duty to Minimise Delay**

6.3.1 Each Party shall at all times use all reasonable endeavours to minimise any delay in the performance of the Contract as a result of Force Majeure.

6.3.2 A Party shall give notice to the other Party when it ceases to be affected by the Force Majeure.

### **6.4 Consequences of Force Majeure**

6.4.1 If the Contractor is prevented from performing its substantial obligations under the Contract by Force Majeure of which notice has been given under GC Clause 6.2 [Notice of Force Majeure], and suffers delay and/or incurs Cost by reason of such Force Majeure, the Contractor shall be entitled subject to GC Clause 1.32.1 [Procedure for Disputes] to:

- (a) an extension of time for any such delay, if completion is or will be delayed, under GC Clause 2.2 [Extension of the Intended Completion Date], and
- (b) if the event or circumstance is of the kind described in sub-paragraphs (i) to (iv) of GC Clause 6.1 [Definition of Force Majeure] and, in the case of GC Clause 6.1.1(d)(ii) to (iv), occurs in the Country, payment of any such Cost, including the costs of rectifying or replacing the Works and/or Goods damaged or destroyed by Force Majeure, to the extent they are not indemnified through the insurance policy referred to in GC Clause 1.21 [Insurance].

6.4.2 After receiving this notice, the Project Manager shall proceed in accordance with GC Clause 1.13 [Project Manager's Decisions] to agree or determine these matters.

### **6.5 Force Majeure Affecting Subcontractor**

6.5.1 If any Subcontractor is entitled under any contract or agreement relating to the Works to relief from force majeure on terms additional to or broader than those specified in this Clause, such additional or broader force majeure events or circumstances shall not excuse the Contractor's non-performance or entitle him to relief under this Clause.

### **6.6 Optional Termination, Payment and Release**

6.6.1 If the execution of substantially all the Works in progress is prevented for a continuous period of 84 days by reason of Force Majeure of which notice has been given under GC Clause 6.2 [Notice of Force Majeure], or for multiple periods which total more than 140 days due to the same notified Force Majeure, then either Party may give to the other Party a notice of termination of the

Contract. In this event, the termination shall take effect 7 days after the notice is given, and the Contractor shall proceed in accordance with **GC** Clause 7.5.5.

6.6.2 Upon such termination, the Project Manager shall determine the value of the work done and issue a Payment Certificate which shall include:

- (a) the amounts payable for any work carried out for which a price is stated in the Contract;
- (b) the Cost of Plant and Materials ordered for the Works which have been delivered to the Contractor, or of which the Contractor is liable to accept delivery: this Plant and Materials shall become the property of (and be at the risk of) the Employer when paid for by the Employer, and the Contractor shall place the same at the Employer's disposal;
- (c) other Costs or liabilities which in the circumstances were reasonably and necessarily incurred by the Contractor in the expectation of completing the Works;
- (d) the Cost of removal of Temporary Works and Contractor's Equipment from the Site and the return of these items to the Contractor's works in his country (or to any other destination at no greater cost); and
- (e) the Cost of repatriation of the Contractor's staff and labour employed wholly in connection with the Works at the date of termination.

## **6.7 Release from Performance**

6.7.1 Notwithstanding any other provision of this Clause, if any event or circumstance outside the control of the Parties (including, but not limited to, Force Majeure) arises which makes it impossible or unlawful for either or both Parties to fulfill its or their contractual obligations or which, under the law governing the Contract, entitles the Parties to be released from further performance of the Contract, then upon notice by either Party to the other Party of such event or circumstance:

- (a) the Parties shall be discharged from further performance, without prejudice to the rights of either Party in respect of any previous breach of the Contract, and
- (b) the sum payable by the Employer to the Contractor shall be the same as would have been payable under **GC** Clause 6.6 [Optional Termination, Payment and Release] if the Contract had been terminated under **GC** Clause 6.6.

## **7. Finishing the Contract**

### **7.1 Completion**

7.1.1 The Contractor shall request the Project Manager to issue a Certificate of Completion of the Works, and the Project Manager shall do so upon deciding that the whole of the Works is completed.

### **7.2 Taking Over**

7.2.1 The Employer shall take over the Site and the Works within seven days of the Project Manager's issuing a certificate of Completion.

### **7.3 Final Account**

7.3.1 The Contractor shall supply the Project Manager with a detailed account of the total amount that the Contractor considers payable under the Contract before the end of the Defects Liability Period. The Project Manager shall issue a Defects Liability Certificate and certify any final payment that is due to the Contractor within 56 days of receiving the Contractor's account if it is correct and complete. If it is not, the Project Manager shall issue within 56 days a schedule that states the scope of the corrections or additions that are necessary. If the Final Account is still unsatisfactory after it has been resubmitted, the Project Manager shall decide on the amount payable to the Contractor and issue a payment certificate.

### **7.4 Operating and Maintenance Manuals**

7.4.1 If "as built" Drawings and/or operating and maintenance manuals are required, the Contractor shall supply them by the dates stated in the **PC**.

7.4.2 If the Contractor does not supply the Drawings and/or manuals by the dates stated in the **PC** pursuant to **GC** Clause 7.4.1, or they do not receive the Project Manager's approval, the Project Manager shall withhold the amount stated in the **PC** from payments due to the Contractor.

### **7.5 Termination**

7.5.1 The Employer or the Contractor may terminate the Contract if the other party causes a fundamental breach of the Contract.

7.5.2 Fundamental breaches of Contract shall include, but shall not be limited to, the following:

- (a) the Contractor stops work for 28 days when no stoppage of work is shown on the current Programme and the stoppage has not been authorized by the Project Manager;
- (b) the Project Manager instructs the Contractor to delay the progress of the Works, and the instruction is not withdrawn within 28 days;
- (c) the Employer or the Contractor is made bankrupt or goes into liquidation other than for a reconstruction or amalgamation;

- (d) a payment certified by the Project Manager is not paid by the Employer to the Contractor within 84 days of the date of the Project Manager's certificate;
- (e) the Project Manager gives Notice that failure to correct a particular Defect is a fundamental breach of Contract and the Contractor fails to correct it within a reasonable period of time determined by the Project Manager;
- (f) the Contractor does not maintain a Security, which is required;
- (g) the Contractor has delayed the completion of the Works by the number of days for which the maximum amount of liquidated damages can be paid, as defined in the **PC**; or
- (h) if the Contractor, as determined by the Employer, based on reasonable evidence, has engaged in corrupt or fraudulent practices in competing for or in executing the Contract, pursuant to **GC** Clause 7.6 [Fraud and Corruption].

7.5.3 When either party to the Contract gives notice of a breach of Contract to the Project Manager for a cause other than those listed under **GC** Clause 7.5.2 above, the Project Manager shall decide whether the breach is fundamental or not.

7.5.4 Notwithstanding the above, the Employer may terminate the Contract for convenience.

7.5.5 If the Contract is terminated, the Contractor shall stop work immediately, make the Site safe and secure, and leave the Site as soon as reasonably possible.

## **7.6 Fraud and Corruption**

7.6.1 If the Employer determines that the Contractor has engaged in corrupt, fraudulent, collusive or coercive practices, in competing for or in executing the Contract, then the Employer may, after giving 14 days notice to the Contractor, terminate the Contractor's employment under the Contract and expel him from the Site, and the provisions of **GC** Clause 7.5 [Termination] shall apply as if such expulsion had been made under **GC** Clause 7.5.2.

7.6.2 Should any employee of the Contractor be determined to have engaged in corrupt, fraudulent or coercive practice during the execution of the work then that employee shall be removed in accordance with **GC** Clause 1.16.2.

7.6.3 It is the Bank's policy to require that Borrowers (including beneficiaries of Bank Financing), as well as bidders, suppliers, and contractors, and their subcontractors, under Bank-financed contracts, observe the highest standard of ethics during the procurement and execution of such contracts. In pursuance of this policy<sup>14</sup>, the Bank:

- (a) defines, for the purposes of this provision, the terms set forth below as follows:

<sup>14</sup> See the Bank's "Rules and Procedures for Whistleblowing and Complaints Handling in the Bank"; and the "Guidelines for Preventing & Combating Corruption & Fraud in Bank Group Operations"

- (i) “Corrupt Practice” is the offering, giving, receiving, or soliciting, directly or indirectly, of anything of value to influence improperly the actions of another party;
  - (ii) “Fraudulent Practice” is any act or omission, including a misrepresentation that knowingly or recklessly misleads, or attempts to mislead, a party to obtain financial or other benefit or to avoid an obligation;
  - (iii) “Collusive Practice” is an arrangement between two or more parties, designed to achieve an improper purpose, including to influence improperly the actions of another party; and
  - (iv) “Coercive Practice” is impairing or harming, or threatening to impair or harm, directly or indirectly, any party or the property of the party to influence improperly the actions of a party;
- (b) will reject a proposal for award if it determines that the bidder recommended for award has, directly or through an agent, engaged in Corrupt, Fraudulent, Collusive, or Coercive Practices in competing for the contract in question;
- (c) will cancel the portion of the Financing allocated to a contract if it determines at any time that representatives of the Borrower or of a beneficiary of such Financing engaged in Corrupt, Fraudulent, Collusive, or Coercive Practices during the procurement or the execution of that contract, without the Borrower having taken timely and appropriate action satisfactory to the Bank to address such practices when they occur;
- (d) will sanction a firm or individual, including declaring such firm or individual ineligible to bid for, or to be awarded Bank-financed contracts either indefinitely or for a stated period of time, if it at any time determines that the firm or individual has, directly or through an agent, engaged in Corrupt, Fraudulent, Collusive, or Coercive Practices in competing for, or in executing, a Bank-financed contract; and
- (e) will have the right to require that a provision be included in bidding documents and in contracts financed by the Bank, requiring bidders, suppliers and contractors to permit the Bank to inspect their accounts and records and other documents relating to the bid submission and contract performance and to have them audited by auditors appointed by the Bank.

## **7.7 Payment upon Termination**

- 7.7.1 If the Contract is terminated because of a fundamental breach of Contract by the Contractor, the Project Manager shall issue a certificate for the value of the work done and Materials ordered less advance payments received up to the date of the issue of the certificate and less the percentage to apply to the value of the work not completed, as indicated in the **PC**. Additional Liquidated Damages shall not apply. If the total amount due to the Employer exceeds any payment due to the Contractor, the difference shall be a debt payable to the Employer.

7.7.2 If the Contract is terminated for the Employer's convenience or because of a fundamental breach of Contract by the Employer, the Project Manager shall issue a certificate for the value of the work done, Materials ordered, the reasonable cost of removal of Equipment, repatriation of the Contractor's personnel employed solely on the Works, and the Contractor's costs of protecting and securing the Works, and less advance payments received up to the date of the certificate.

## **7.8 Property**

7.8.1 All Materials on the Site, Plant, Equipment, Temporary Works, and Works shall be deemed to be the property of the Employer if the Contract is terminated because of the Contractor's default.

## **7.9 Release from Performance**

7.9.1 If the Contract is frustrated by the outbreak of war or by any other event entirely outside the control of either the Employer or the Contractor, the Project Manager shall certify that the Contract has been frustrated. The Contractor shall make the Site safe and stop work as quickly as possible after receiving this certificate and shall be paid for all work carried out before receiving it and for any work carried out afterwards to which a commitment was made.

## **7.10 Suspension of Bank Financing**

7.10.1 In the event that the Bank suspends the Financing to the Employer, from which part of the payments to the Contractor are being made:

- (a) The Employer is obligated to notify the Contractor of such suspension within 7 days of having received the Bank's suspension notice.
- (b) If the Contractor has not received sums due it within the 28 days for payment provided for in **GC** Clause 4.6.1, the Contractor may immediately issue a 14-day termination notice.

## **7.11 Eligibility<sup>15</sup>**

7.11.1 The Contractor shall have the nationality from an eligible country of the Bank in accordance with the Bank's **Rules and Procedures for Procurement of Goods and Works**, as listed in Section V, Eligible Countries. The Contractor shall be deemed to have the nationality of a country if the Contractor is a citizen or is constituted, or incorporated, and operates in conformity with the provisions of the laws of that country. This criterion shall also apply to the determination of the nationality of proposed subcontractors or suppliers for any part of the Contract including related services.

7.11.2 The materials, equipment and services to be supplied under the Contract shall have their origin in eligible source countries and all expenditures under the Contract will be limited to such materials, equipment, and services. At the

---

<sup>15</sup> For the purposes of Eligibility, the provisions of the Bank's **Rules and Procedures for Procurement of Goods and Works** have been presented in detail at Section V, Eligible Countries.



Employer's request, the Contractor may be required to provide evidence of the origin of materials, equipment and services.

- 7.11.3 For purposes of **GC** Clause 7.11.1, "origin" means the place where the materials and equipment are mined, grown, produced or manufactured, and from which the services are provided. Materials and equipment are produced when, through manufacturing, processing, or substantial or major assembling of components, a commercially recognized product results that differs substantially in its basic characteristics or in purpose or utility from its components.



## Section VIII. Particular Conditions

Except where otherwise indicated, all **PC** should be filled in by the Employer prior to issuance of the Bidding Documents. Schedules and reports to be provided by the Employer should be annexed.

<b>1. General Provisions</b>	
<b>GC 1.1.2.2</b>	The Employer is: <b>Kenya Forest Service, Karura, Off-Kiambu Road, P.O. Box 30513 -00100, Nairobi Kenya Tel 020 2502508, Fax 020 2385372</b>  <b>Email: director@kenyaforests-service.org</b>
<b>GC 1.1 .2.4</b>	The Project Manager is: <b>Jerome Mwanzia, Project Manager, Green Zones Development Support Project Phase II, P.O. Box 30513-00100 Nairobi Tel +254 20 3536889</b>  <b>Email: jmwanzia@kenyaforests-service.org</b>
<b>GC 1.1.2.6</b>	The Bank is: <b>AFRICAN DEVELOPMENT FUND (ADF)</b>
<b>GC 1.1.2.7</b>	The Borrower is: <b>GOVERNMENT OF KENYA</b>
<b>GC 1.1.3.2</b>	The Commencement Date shall be: <b>Not more than 14 days after site hand-over</b>
<b>GC 1.1.3.3</b>	The Completion Date for the whole of the Works shall be: <b>12 months after commencement date</b>
<b>GC 1.1.5.6</b>	If Sections are to be used: <b>N/A</b>
<b>GC 1.1.5.8</b>	The Works consist of: <b>Construction of Community Resource Centre at Kenya Forest Service Headquarters at Karura.</b>
<b>GC 1.1.6.6</b>	The Sites are located at Kenya Forest Service Headquarters at Karura and is defined in Drawing Nos: <b>Section IV</b>
<b>GC 1.2.3</b>	Sectional Completions <b>shall not be</b> applicable.

<b>GC 1.2.4(i)</b>	<p>The following documents also form part of the Contract:</p> <ul style="list-style-type: none"> <li>• <b>Letter of acceptance</b></li> <li>• <b>The bid</b></li> <li>• <b>The particular conditions</b></li> <li>• <b>General Conditions</b></li> <li>• <b>The specifications</b></li> <li>• <b>The drawings</b></li> <li>• <b>Bills of Quantities</b></li> </ul>
<b>GC 1.3.1(a)</b>	The Electronic Transmission System is: <b>N/A</b>
<b>GC 1.3.1(b)</b>	<p>The Employer's address for the purpose of communications is:</p> <p><b>Chief Conservator of Forests , Kenya Forest Service, Karura, Off-Kiambu Road P.O. Box 30513-00100 Nairobi, Kenya</b></p> <p>Tel: <b>020 2502508,</b> <b>Fax 020 2385372</b></p> <p><b>Email: director@kenyaforestservice.org</b></p> <p>The Contractor's address for the purpose of communications is: <b>[state full address, telephone, fax and e-mail]</b></p>
<b>GC 1.4.1</b>	<p>The governing law is that of: <b>Kenya</b></p> <p>The ruling language is: <b>English</b></p> <p>The language for communications is: <b>English</b></p>
<b>GC 1.6.1</b>	The Parties <b>shall</b> enter into contract within 28 days after the Employer receives the Letter of Acceptance
<b>GC 1.10.2(a)</b>	Permits, approvals and/or licenses, or public service undertakings to be acquired by the Employer: <b>N/A</b>
<b>GC 1.10.2(b)</b>	Permits, approvals and/or licenses, or public service undertakings to be acquired by the Contractor: <b>N/A</b>

<b>GC 1.11.1</b>	The individuals or firms in a joint venture, consortium or association <b>shall be</b> jointly and severally liable.
<b>GC 1.17.1</b>	Schedule of Other Contractors: <b>N/A</b>
<b>GC 1.21.1</b>	The minimum insurance amounts and deductibles shall be: (a) for loss or damage to the Works, Plant and Materials: <b>N/A</b> (b) for loss or damage to Equipment: <b>N/A</b> (c) for loss or damage to property (except the Works, Plant, Materials, and Equipment) in connection with Contract: <b>N/A</b> (d) for personal injury or death: (i) of the Contractor's employees: <b>N/A</b> (ii) of other people: <b>N/A</b>
<b>GC 1.22.1</b>	Site Investigation Reports shall include: <b>N/A</b>
<b>GC 1.28.1</b>	The Site Possession Date(s) shall be: <b>To be agreed upon by employer &amp; contractor</b>
<b>GC 1.31.1 &amp; 1.31.2</b>	Appointing Authority for the Adjudicator: <b>Chartered Institute of Arbitrators Kenya Chapter</b>
<b>GC 1.32.3</b>	Hourly rate and types of reimbursable expenses to be paid to the Adjudicator: <b>Prevailing rates for consultants</b>
<b>GC 1.32.4</b>	[For smaller contracts, the institution is usually from the Employer's country. For larger contracts, and contracts that are likely to be awarded to international contractors, it is recommended that the arbitration procedures of an international institution be utilised]:  Institution whose arbitration procedures shall be used: <b>Chartered Institute of Arbitrators Kenya Chapter</b>  The place of arbitration shall be: <b>Nairobi, Kenya</b>
<b>2. Time Control</b>	
<b>GC 2.1.1</b>	The Contractor shall submit for approval a Programme for the Works within <b>14</b> days from the date of the Letter of Acceptance.
<b>GC 2.1.3</b>	The period between Programme updates is <b>30</b> days.  The amount to be withheld for late submission of an updated Programme is: <b>10%</b>

<b>3. Quality Control</b>	
<b>GC 3.3.1</b>	The Defects Liability Period is: <b>180</b> days.  <i>[The Defects Liability Period is usually limited to 12 months, but could be less in very simple cases]</i>
<b>4. Cost Control</b>	
<b>GC 4.9.1</b>	The currency of the Employer's country is: <b>KENYA SHILLINGS</b>
<b>GC 4.10.1</b>	The Contract <b>shall not</b> be subject to price adjustment, in accordance with <b>GC</b> Clause 4.10.1, and the following information regarding coefficients <b>shall not</b> apply.
<b>GC 4.11.1</b>	The proportion of payments retained is: <b>10%</b>  <i>[The retention amount is usually to be kept close to 5 percent and shall in no case exceed 10 percent.]</i>
<b>GC 4.12.1</b>	The Liquidated Damages for the whole of the Works are <b>0.05%</b> of the final Contract Price, per day. The maximum amount of Liquidated Damages for the whole of the Works is <b>5%</b> of the final Contract Price.  <i>[Usually liquidated damages are set between 0.05 percent and 0.10 percent per day, and the total amount is not to exceed between 5 percent and 10 percent of the Contract Price. If Sectional Completion and Damages per Section have been agreed, the latter should be specified here]</i>
<b>GC 4.13.1</b>	The Bonus for the whole of the Works: <b>N/A</b>
<b>GC 4.14.1</b>	The Advance Payment shall be: <b>N/A</b>
<b>GC 4.15.1</b>	The Performance Security amount is in the form of:  Bank Guarantee: <b>10%</b> of the contract sum
<b>7. Finishing the Contract</b>	
<b>GC 7.4.1</b>	The date by which operating and maintenance manuals are required shall be: <b>[ Seven days after Practical Completion]</b>  The date by which "as built" drawings are required shall be: <b>[Seven days after Practical Completion]</b>
<b>GC 7.4.2</b>	The amount to be withheld for failing to produce "as built" drawings and/or

	operating and maintenance manuals by the date required in <b>GC Clause 7.7.1</b> shall be: <b>kshs 250,000</b>
<b>GC 7.5.2 (g)</b>	The maximum number of days within which to provide 'as built' drawings is: <b>7 days</b> after completion
<b>GC 7.7.1</b>	The percentage to apply to the value of the work not completed, representing the Employer's additional cost for completing the Works, shall be: <b>5%</b>





## **Section IX. Contract Forms**

This Section contains Contract Forms which, once completed, will constitute part of the Contract. The forms for Contract Agreement, Performance Security and Advance Payment Security, when required, shall only be completed by the successful Bidder, after contract award

### **Table of Forms**

<b>Letter of Acceptance</b>	<b>134</b>
<b>Contract Agreement</b>	<b>135</b>
<b>Option I: Performance Security</b>	<b>137</b>
<b>Option II: Performance Bond</b>	<b>139</b>
<b>Advance Payment Security</b>	<b>141</b>
<b>Retention Money Security</b>	<b>143</b>

## Letter of Acceptance

[on letterhead paper of the Employer]

..... [date]. .....

To: [name and address of the Contractor] .....

Subject: [Notification of Award Contract No]. .....

This is to notify you that your Bid dated . . . . [Insert date] . . . . for execution of the . . . . .  
. [insert name of the contract and identification number] ..... for the amount of . .  
..... [insert amount (s) in figures and words and name(s) of currency(ies)], as corrected  
and modified in accordance with the Instructions to Bidders is hereby accepted by us.

You are requested to furnish the Performance Security in the amount of [insert amount (s) in  
**figures and words and name(s) of currency(ies)**] within 28 days<sup>16</sup> in accordance with the  
Conditions of Contract, using for that purpose the Performance Security Form included in  
Section IX (Contract Forms) of the Bidding Document.

We accept the appointment of [Employer to insert full name and address of alternative  
**appointee proposed by Bidder in Letter of Bid**] as the Adjudicator. / We do not accept the  
appointment of [Employer to insert full name and address of alternative appointee  
**proposed by Bidder in Letter of Bid**] as the Adjudicator. And, consequently, the provisions  
of GC Clause 1.31 shall apply.<sup>17</sup>

Authorized Signature: .....

Name and Title of Signatory: .....

Name of Agency: .....

Attachment: Contract Agreement

---

<sup>16</sup> Or, the alternative deadline stipulated in the **Particular Conditions**.  
<sup>17</sup> Use one of the two options as appropriate.

## Contract Agreement

THIS CONTRACT AGREEMENT is made on the [ **insert: number** ] day of [ **insert: month** ], [ **insert: year** ].

BETWEEN

(1) [ **insert complete name of the Employer** ], a [ **insert description of type of legal entity, for example, an agency of the Ministry of ....** ] of the Government of { **insert name of Country of the Employer** }, or corporation incorporated under the laws of { **insert name of Country of the Employer** } and having its principal place of business at [ **insert address of the Employer** ] (hereinafter called “the Employer”),

and

(2) [ **insert name of the Contractor** ], a corporation incorporated under the laws of [ **insert: country of Contractor** ] and having its principal place of business at [ **insert: address of Contractor** ] (hereinafter called “the Contractor”).

WHEREAS the Employer invited bids for the Works, described as [ **insert brief description of the Works** ] and has accepted a Bid by the Contractor for the execution and completion of these Works and the remedying of any defects therein, and the Employer agrees to pay the Contractor the Contract Price or such other sum as may become payable under the provisions of the Contract at the times and in the manner prescribed by the Contract.

The Employer and the Contractor agree as follows:

1. In this Agreement words and expressions shall have the same meanings as are respectively assigned to them in the Contract documents referred to.
2. The following documents shall be deemed to form and be read and construed as part of this Agreement. This Agreement shall prevail over all other Contract documents.

- (a) the Letter of Acceptance
- (b) the Bid
- (c) the Addenda Nos . . . . . [ **insert addenda numbers if any** ]. . . . .
- (d) the Particular Conditions
- (e) the General Conditions
- (f) the Specification
- (g) the Drawings; and

(h) the completed Schedules,

3. In consideration of the payments to be made by the Employer to the Contractor as indicated in this Agreement, the Contractor hereby covenants with the Employer to execute the Works and to remedy defects therein in conformity in all respects with the provisions of the Contract.

4. The Employer hereby covenants to pay the Contractor in consideration of the execution and completion of the Works and the remedying of defects therein, the Contract Price or such other sum as may become payable under the provisions of the Contract at the times and in the manner prescribed by the Contract.

Agreement to be executed in accordance with the laws of.....**[insert name of the borrowing country]**.....on the day, month and year indicated above.

Signed by:

Signed by:

For and on behalf of the Employer

for and on behalf the Contractor

In the presence of:

in the presence of:

**Witness, Name, Signature, Address, Date**

**Witness, Name, Signature, Address, Date**

## Option I: Performance Security

[The bank, as requested by the successful Bidder, shall fill in this form in accordance with the instructions indicated]

Date: **[insert date (e.g., day, month, and year)]**

Bidding Process Reference: **[insert no. and title of bidding process]**

Bank's Branch or Office: **[insert complete name of Guarantor]**

**Beneficiary:** **[insert complete name of Employer]**

**PERFORMANCE GUARANTEE No.:** **[insert Performance Guarantee number]**

We have been informed that **[insert complete name of the Contractor]** (hereinafter called "the Contractor") has entered into Contract No. **[insert number]** dated **[insert day and month]**, **[insert year]** with you, for the execution and completion of **[insert description of the Works]** and the remedying of any defects therein (hereinafter called "the Contract").

Furthermore, we understand that, according to the conditions of the Contract, a Performance Guarantee is required.

At the request of the Employer, we hereby irrevocably undertake to pay you any sum(s) not exceeding **[insert amount(s)<sup>18</sup> in figures and words]** such sum being payable in the types and proportions of currencies in which the Contract Price is payable, upon receipt by us of your first demand in writing declaring the Contractor to be in default under the Contract, without cavil or argument, or your needing to prove or to show grounds or reasons for your demand or the sum specified therein.

---

<sup>18</sup> The Bank shall insert the amount(s) specified in the **PC** and denominated, as specified in the **PC**, either in the currency(ies) of the Contract or a freely convertible currency acceptable to the Employer.

This Guarantee shall expire no later than the **[insert number]** day of **[insert month]**, **[insert year]**,<sup>19</sup> and any demand for payment under it must be received by us at this office on or before that date. This guarantee is subject to the Uniform Rules for Demand Guarantees, ICC Publication No. 458, except that subparagraph (ii) of Sub-article 20(a) is hereby excluded.

**[signatures of authorized representatives of the bank]**

---

<sup>19</sup> Insert the date twenty-eight days after the expected completion date. The Employer should note that in the event of an extension of the time for completion of the Contract, the Employer would need to request an extension of this guarantee from the Guarantor. Such request must be in writing and must be made prior to the expiration date established in the guarantee. In preparing this guarantee, the Employer might consider adding the following text to the form, at the end of the penultimate paragraph: “The Guarantor agrees to a one-time extension of this guarantee for a period not to exceed **[six months]****[one year]**, in response to the Employer’s written request for such extension, such request to be presented to the Guarantor before the expiry of the guarantee.”]

## Option II: Performance Bond

By this Bond \_\_\_\_\_ as Principal (hereinafter called “the Contractor”) and \_\_\_\_\_] as Surety (hereinafter called “the Surety”), are held and firmly bound unto \_\_\_\_\_] as Obligee (hereinafter called “the Employer”) in the amount of \_\_\_\_\_, for the payment of which sum well and truly to be made in the types and proportions of currencies in which the Contract Price is payable, the Contractor and the Surety bind themselves, their heirs, executors, administrators, successors and assigns, jointly and severally, firmly by these presents.

WHEREAS the Contractor has entered into a written Agreement with the Employer dated the \_\_\_\_\_ day of \_\_\_\_\_, 20 \_\_, for \_\_\_\_\_ in accordance with the documents, plans, specifications, and amendments thereto, which to the extent herein provided for, are by reference made part hereof and are hereinafter referred to as the Contract.

NOW, THEREFORE, the Condition of this Obligation is such that, if the Contractor shall promptly and faithfully perform the said Contract (including any amendments thereto), then this obligation shall be null and void; otherwise, it shall remain in full force and effect. Whenever the Contractor shall be, and declared by the Employer to be, in default under the Contract, the Employer having performed the Employer’s obligations thereunder, the Surety may promptly remedy the default, or shall promptly:

- (1) complete the Contract in accordance with its terms and conditions; or
- (2) obtain a Bid or bids from qualified Bidders for submission to the Employer for completing the Contract in accordance with its terms and conditions, and upon determination by the Employer and the Surety of the lowest responsive Bidder, arrange for a Contract between such Bidder and Employer and make available as work progresses (even though there should be a default or a succession of defaults under the Contract or Contracts of completion arranged under this paragraph) sufficient funds to pay the cost of completion less the Balance of the Contract Price; but not exceeding, including other costs and damages for which the Surety may be liable hereunder, the amount set forth in the first paragraph hereof. The term “Balance of the Contract Price,” as used in this paragraph, shall mean the total amount payable by Employer to Contractor under the Contract, less the amount properly paid by Employer to Contractor; or
- (3) pay the Employer the amount required by Employer to complete the Contract in accordance with its terms and conditions up to a total not exceeding the amount of this Bond.

The Surety shall not be liable for a greater sum than the specified penalty of this Bond.

Any suit under this Bond must be instituted before the expiration of one year from the date of the issuing of the Taking-Over Certificate.

No right of action shall accrue on this Bond to or for the use of any person or corporation other than the Employer named herein or the heirs, executors, administrators, successors, and assigns of the Employer.

In testimony whereof, the Contractor has hereunto set his hand and affixed his seal, and the Surety has caused these presents to be sealed with his corporate seal duly attested by the signature of his legal representative, this \_\_\_\_\_ day of \_\_\_\_\_ 20\_\_.



## Advance Payment Security

[The bank, as requested by the successful Bidder, shall fill in this form in accordance with the instructions indicated.]

Date: **[insert date (e.g., day, month, and year) of Bid Submission]**

Bidding Process Reference: **[insert number and title of bidding process]**

**[bank's letterhead]**

**Beneficiary: [insert legal name and address of Employer]**

**ADVANCE PAYMENT GUARANTEE No.: [insert Advance Payment Guarantee no.]**

We have been informed that . . . . . **[insert name of the Contractor]** (hereinafter called "the Contractor") has entered into Contract No. . . . . **[insert reference number of the Contract]**. . . . dated **[insert day and month]**, **[insert year]**. . . . . with you, for the execution of.....**[insert name of contract and brief description of Works]** (hereinafter called "the Contract").

Furthermore, we understand that, according to the Conditions of the Contract, an advance payment in the sum .. **[insert currency and amount in figures]**<sup>20</sup>. . . . (..... **[insert currency and amount in words]** ) is to be made against an advance payment guarantee.

At the request of the Employer, we . . . . . **[insert name of the Bank]** hereby irrevocably undertake to pay you any sum or sums not exceeding in total an amount of..... **[insert currency and amount in figures]\***. . . . . ( . . . . . **[insert currency and amount in words]**. . . . . ) upon receipt by us of your first demand in writing accompanied by a written statement stating that the Contractor is in breach of its obligation under the Contract because the Contractor used the advance payment for purposes other than performing his obligations under the Contract or the costs of mobilization in respect of the Works.

It is a condition for any claim and payment under this guarantee to be made that the advance payment referred to above must have been received by the Contractor on its account number . . . . . **[insert Contractor's account number]**. . . . . at.....**[insert name and address of the Bank]**. . . . .

<sup>20</sup> The Guarantor shall insert an amount representing the amount of the advance payment denominated either in the currency(ies) of the advance payment as specified in the Contract, or in a freely convertible currency acceptable to the Employer

The maximum amount of this guarantee shall be progressively reduced by the amount of the advance payment repaid by the Contractor as indicated in copies of interim statements or payment certificates which shall be presented to us. This guarantee shall expire, at the latest, upon our receipt of a copy of the interim payment certificate indicating that eighty (80) percent of the Contract Price has been certified for payment, or on the . . . day of . . . . ., . . . . .<sup>21</sup>, whichever is earlier. Consequently, any demand for payment under this guarantee must be received by us at this office on or before that date.

This guarantee is subject to the Uniform Rules for Demand Guarantees, ICC Publication No. 458, except that subparagraph (ii) of Sub-article 20(a) is hereby excluded..

. . . . . [Seal of Bank and Signature(s)]. . . . .

**Note –**

**All italicized text (including footnotes) is for guidance on how to prepare this demand guarantee and shall be deleted from the final document.**

---

<sup>21</sup> Insert the expected expiration date of the Time for Completion. The Employer should note that in the event of an extension of the time for completion of the Contract, the Employer would need to request an extension of this guarantee from the Guarantor. Such request must be in writing and must be made prior to the expiration date established in the guarantee. In preparing this guarantee, the Employer might consider adding the following text to the form, at the end of the penultimate paragraph: “The Guarantor agrees to a one-time extension of this guarantee for a period not to exceed [insert number of months], in response to the Employer’s written request for such extension, such request to be presented to the Guarantor before the expiry of the guarantee.”

## Retention Money Security

### Demand Guarantee

\_\_\_\_\_ [insert Bank's Name, and Address of Issuing Branch or Office]

**Beneficiary:** \_\_\_\_\_ [insert Name and Address of Employer]

**Date:** \_\_\_\_\_ [insert date (e.g., day, month, and year)]

**RETENTION MONEY GUARANTEE No.:** [insert Retention Money Guarantee no.]

We have been informed that \_\_\_\_\_ [insert name of Contractor] (hereinafter called "the Contractor") has entered into Contract No. \_\_\_\_\_ [insert reference number of contract] dated \_\_\_\_\_ [insert date] with you, for the execution of \_\_\_\_\_ [insert name of contract and brief description of Works] (hereinafter called "the Contract").

Furthermore, we understand that, according to the conditions of the Contract, when the Taking-Over Certificate has been issued for the Works and the first half of the Retention Money has been certified for payment, payment of [insert either "the second half of the Retention Money", or, if the amount guaranteed under the Performance Guarantee, when the Taking-Over Certificate is issued, is less than half of the Retention Money, "the difference between half of the Retention Money and the amount guaranteed under the Performance Security"] is to be made against a Retention Money guarantee.

At the request of the Employer, we \_\_\_\_\_ [insert name of Bank] hereby irrevocably undertake to pay you any sum or sums not exceeding in total an amount of \_\_\_\_\_ [insert amount in figures] ( ) [insert amount in words]<sup>1</sup> upon receipt by us of your first demand in writing accompanied by a written statement stating that the Contractor is in breach of its obligation under the Contract because the Contractor used the advance payment for purposes other than the costs of mobilization in respect of the Works.

---

<sup>1</sup> *The Guarantor shall insert an amount representing the amount of the second half of the Retention Money or, if the amount guaranteed under the Performance Guarantee when the Taking-Over Certificate is issued is less than half of the Retention Money, the difference between half of the Retention Money and the amount guaranteed under the Performance Security and denominated either in the currency(ies) of the second half of the Retention Money as specified in the Contract, or in a freely convertible currency acceptable to the Employer.*

It is a condition for any claim and payment under this guarantee to be made that the payment of the second half of the Retention Money referred to above must have been received by the Contractor on its account number \_\_\_\_\_ **[insert Contractor's account number]** at \_\_\_\_\_ **[insert name and address of the Bank]**.

This guarantee shall expire, at the latest, 21 days after the date when the Employer has received a copy of the Performance Certificate issued by the Project Manager. Consequently, any demand for payment under this guarantee must be received by us at this office on or before that date.

This guarantee is subject to the Uniform Rules for Demand Guarantees, ICC Publication No. 458.

\_\_\_\_\_  
**[signature(s)]**

**Note: All italicized text (including footnotes) is for use in preparing this form and shall be deleted from the final product.**